

Measurement

Control

Automation

## MAHLO GRAVIMAT FMI

for Tufting Machines

Beta-ray-transmission measurement of weight

**Beta-ray- transmission measurement of total carpet weight;  
offset of primary backing weight**

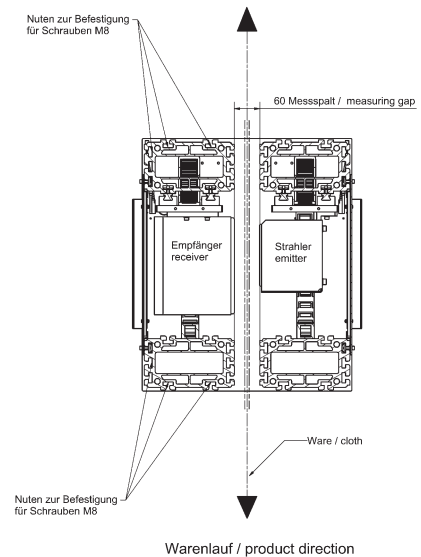
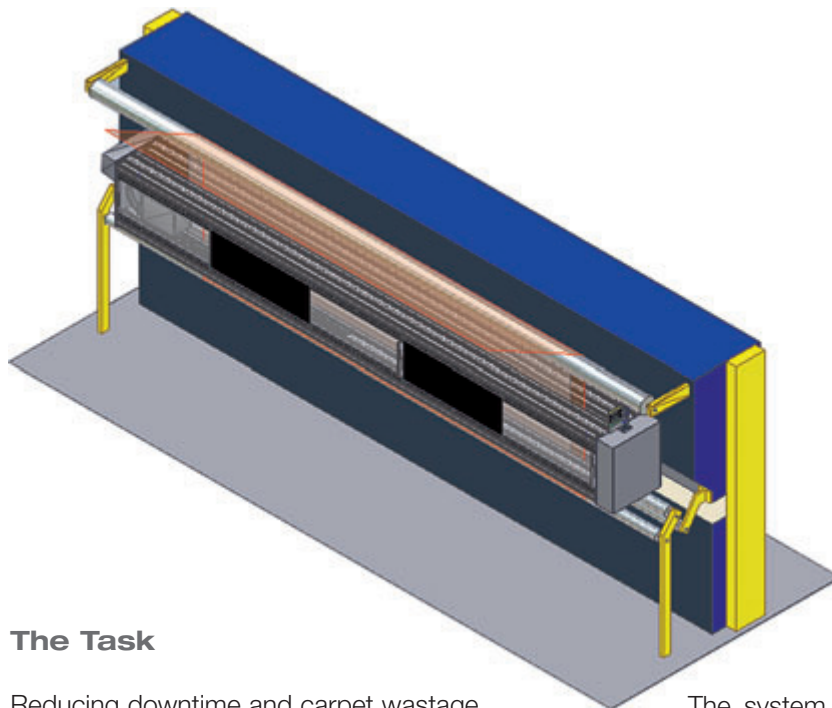

### The Task

Reducing downtime and carpet wastage, compared to conventional methods of pile weight measurement on new styles and product changeover.

The conventional method of determining pile weight of tufted carpet products, is by cutting sample sizes and weighing which leads to downtime and a significant waste of carpet produced.

### The Principal Performance

Beta-ray-transmission measurement of total carpet weight; offset of primary backing weight

The Mahlo **Gravimat FMI** permits quick, accurate, reliable and non destructive measurement of carpet weight. The carpet passes through the measuring gap of a sensor and thereby weakens the beta-rays between its emitter and receiver. The extent to which the carpet weakens the radiation can be transformed into a precise measurement of carpet weight.

The system is optimized for application on tufting machines. The sensor is mounted on a traversing frame and can be driven across the entire width for multiple cross-carpet sampling. A moveable operation unit facilitates the positioning of the sensor to exactly the desired position on the carpet. Single shots of weight values for both primary backing at the selvedge, and the tufted carpet, can be stored. More informative mean values can be calculated and recorded with the easy to operate control software on a touch screen monitor.

Ideally, the system should be installed as close as possible to the needle bar of the tufting machine. Its compact construction guarantees maximum efficiency and user friendliness and also meets the demands of radiation protection.

### The Achievement

Less downtime and wastage of carpet, as opposed to sample cutting, lead to surprisingly fast returns on investment!

Pay back periods of less than 6 months are possible in practical terms. It depends primarily on how close the **Gravimat FMI** is to the tufting needles, the material value, the output figures and frequency of style changes.

## GRAVIMAT FMI

for Tufting Machines

Technical details

### Dimensions:

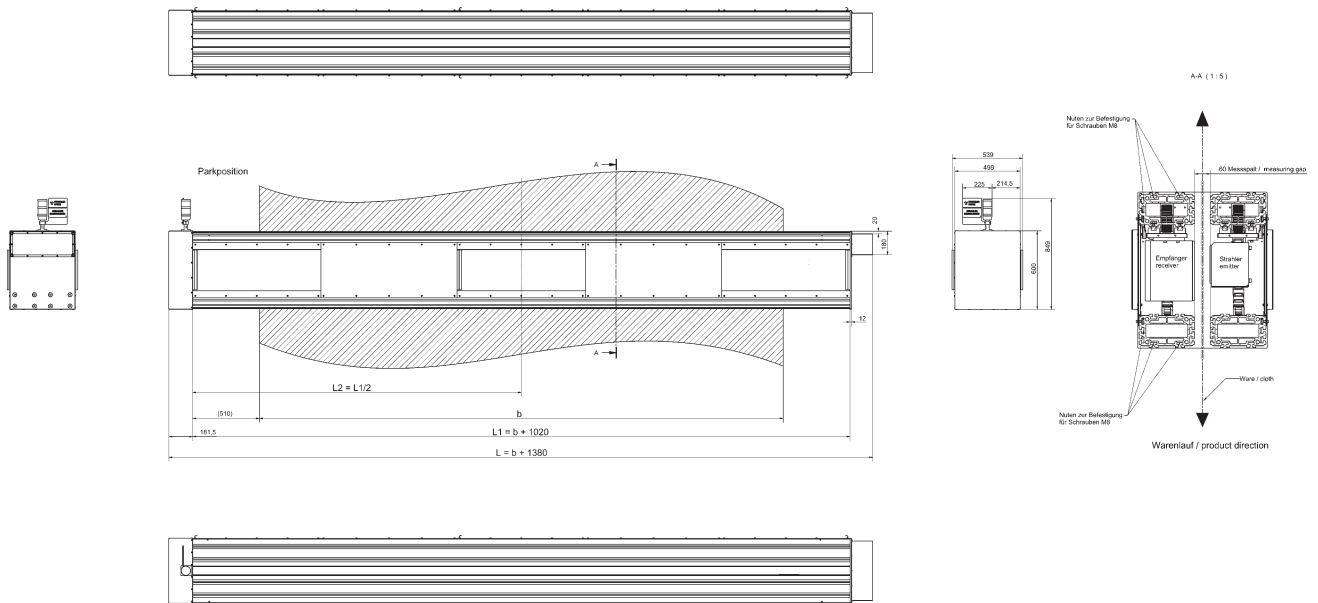

### Technical details:

Type of measurement	Beta-ray-transmission
Isotope	Sr-90
Activity	500MBq / 100MBq
Range	200 - 6000 g/m <sup>2</sup>
Reproducibility (at 20 °C T <sub>amb</sub> )	± 2 g/m <sup>2</sup> at 2000 g/m <sup>2</sup>
Spot diameter	D = 30 mm
Gab width	60 mm
Power supply	230/115V AC 50/60 Hz, max. 1.5 kW
Ambient limits	max. 60 °C, 0-95% relative humidity (non-condensing)