

QUALISCAN® QMS-12

Traversing Quality Control System
for Measurement and Control of Web Processes



QUALISCAN® QMS-12



TEXTILE



NONWOVEN



PAPER



PLASTIC

QUALISCAN® QMS-12

A modular system for measuring, logging, analyzing and controlling critical process parameters over the entire width of the product, including weight per unit area, coating weight, thickness, moisture etc.

Applications

The Qualiscan QMS can be used in virtually every industrial sector in which products are produced as a web, or where they are finished (laminated, coated, etc.). The versatile sensors and measuring devices of the Qualiscan QMS series can sense, log and continuously control such parameters as weight per unit area (basis weight), coating weight, thickness and moisture in a variety of web-type products. The already proven applications range from nonwovens, cast film, film and sheet extrusion, paper, plastic and carpet coatings, textiles, rubber and metal foil to the production of tissue, paper and board.

As a German family-owned company with our own R&D and manufacturing, Mahlo® and our engineers and scientists find it rewarding to work together with our customers to open up completely new and unique areas of application.

Principle of operation

The Qualiscan QMS is a modular system consisting of multiple measuring sensors and traversing frames acting as intelligent nodes on a network. The individual components are linked through a normal Ethernet cable as found in any office for networking multiple PCs.

Product-highlights

- ✓ Modern construction with intelligent sensors and traversing frames
- ✓ Based on industry standard hardened computers running Windows XP™ embedded operating system
- ✓ Components communicate through digital interfaces
- ✓ Audio response for reconfirming main commands
- ✓ Easily expandable with additional measuring locations and sensors



The real-time processors integrated into the sensors and scanning frames allow the majority of measurements to be generated and processed locally, thus the complete measurement data can be transmitted via the network cables quickly and interference-free to the central PC. The latter handles not only control and coordination of the measuring frames, but also visualization and the logging of data, recipes and any desired communication with host systems such as machine controllers, internal DCS systems and other data management, analysis and archiving devices. The network structure facilitates the integration of additional measurement sensors and scanners in the future.



WebPro L scanning frame

Customer benefits

- ✓ Savings in raw materials and / or energy at the manufacturing stage
- ✓ Uninterrupted monitoring and logging of actual product quality
- ✓ Improvement in product quality, especially in conjunction with control
- ✓ Quick return on investment (ROI) and high profit potential

CONTENTS

BASIS

Visualization	6
Everything at a glance	

MECHANICAL

Measuring frame types	
Universal application	
WebPro L, WebPro M	8
WebPro S, WebPro XS	10
UniScan M & S	12

SENSORS

Gravimat DFI	14
Basis weight (mass per unit area) / thickness	
Gravimat FMX	16
Weight per unit area and thickness	
Aqualot AMF/HMF	18
Moisture measurement	
Infralot IMF	20
Moisture measurement, weight per unit area and thickness	
Calipro DML	22
Non-contact measurement of thickness	
Calipro DML-P	24
Contact measurement of thickness	
DieControl APC PRO	26
Auto Die control	
CoatControl CWS	28
Coat weight control	

TECHNICAL DATA

All technical data from page	30
------------------------------	-----------

TRAVERSING QUALITY CONTROL SYSTEM



TEXTILE



NONWOVEN



PAPER



PLASTIC

Key operating features

- + Access to all functions via a rugged, industrial touchscreen
- + Simultaneous representation of up to three lateral or longitudinal profiles of all measured values
- + Efficient recipe management for type-specific measuring and control tasks
- + System access through up to five operating terminals per network
- + Audio response for reconfirming all main commands
- + Generous sizing of all symbols for ease of operation
- + Incorporation and display of important machine functions

Basic components

- + At least one Mahlo® operating and display terminal
- + Central control cabinet with I/O for connection to machine signals
- + At least one Mahlo® scanning frame, or fixed mount measuring devices
- + Tachometers to determine linespeed



Connecting the measuring frames

One or more different scanning frames can be connected to a Qualiscan QMS system. Connection is made via a normal network cable, a standard 230/115 V source supplies the power.

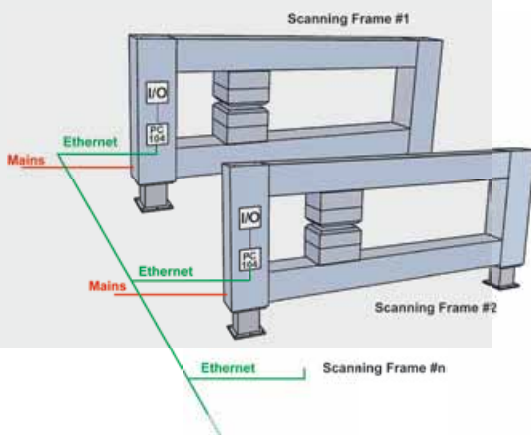

Optional add-ons

- + PRINTSERVER logging system, with output to a printer or drive partition
- + Freely configurable control outputs (PID), with parameter storage in recipes
- + OPC interface (server) for linking to host HMI systems
- + Automatic generation of TEXT or EXCEL™ files with all measured values
- + Connection to a customer's TCP/IP network via configurable switch
- + Air conditioner in all control cabinets and operating terminals for high temperature locations
- + Explosion-proofed scanning frames and sensors in accordance with ATEX 100 and Class 1, Div. 1 standards
- + Dust and corrosion-proofed scanning frames, sensors and control cabinets
- + Water-cooled sensors for unusually high ambient temperatures
- + All components to OEM-specifications for integration into existing systems



WebPro L scanning frame



WebPro M scanning frame

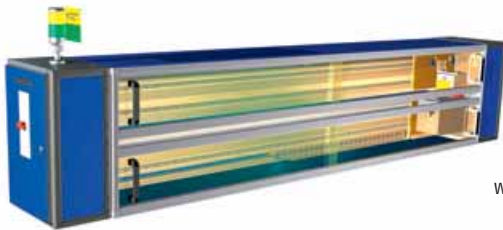

WebPro S scanning frame



WebPro XS scanning frame



UniScan S scanning frame

MAHLO SUPPORT AND CUSTOMER SERVICE

The Mahlo support and service team is at your disposal with expert help whenever you need it:

Online-Support:

SERVICE@MAHLOAMERICA.NET

Support-Hotline:

+1-864-576-6288

mahlo
trendsetting technology. worldwide.



BASIS

VISUALIZATION

EVERYTHING AT A GLANCE

Product-highlights

- ✓ Simultaneous management of various sensors
- ✓ Freely scalable trend diagrams
- ✓ Selectable image scales for histograms
- ✓ Password protection: unauthorised users are denied access to supervisor-selected screens
- ✓ Recipe management
- ✓ Integrated audio response

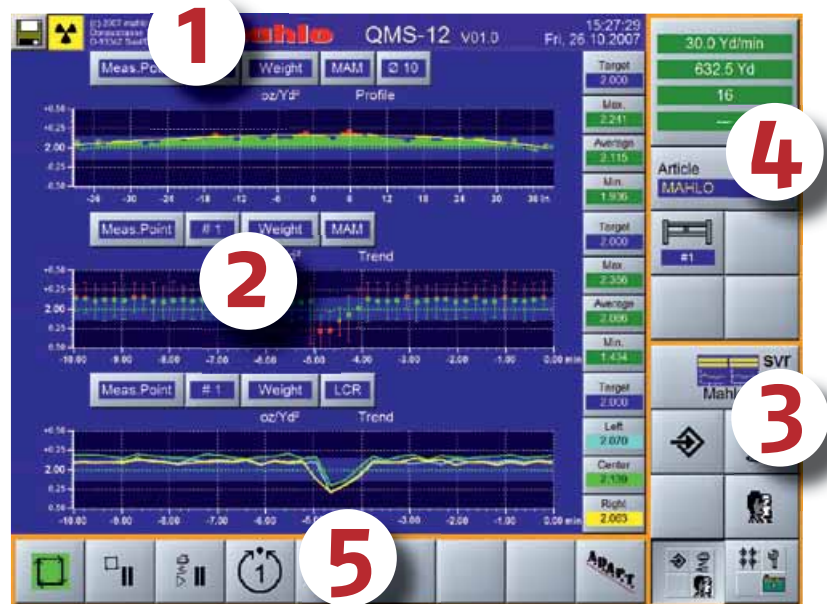

Main page

Customer benefits

- ✓ Menu guide in all common languages
- ✓ Ergonomic user prompting
- ✓ Easy to operate

The user interface consists of five areas:

1. Title line:

General information (including alarm bar)

2. Display area:

Selectable screen pages (display forms)

3. Selection block:

Navigation within the program

4. Vertical block:

Touch buttons for principal options

5. Horizontal block:

Touch buttons for basic functions and sub-options



Main page indicating weight per unit area profile and trend



COMMUNICATION

Our systems talk to you. The touchscreen operated "Human Machine Interface" uses the integrated audio-response facility to give you information on product quality and adherence to tolerances. In any language you wish. So you always know what's happening.



Operating menu for scanning frame

The use of rugged industrial touchscreen technology eliminates mechanical elements such as keys and switches. Everything is entered directly via the screen through large, ergonomic buttons. Audio response in the user's own language represents a huge leap in user-friendliness. Operation of the user-interface is easy and intuitive. All essential information is visible at a glance.



MECHANICAL

MEASURING FRAME TYPES

UNIVERSAL APPLICATION

Principle of operation

A frequency-controlled AC gearmotor drives via a shaft one or two vertically arranged drive belts (one each top and bottom). These are fixed to the scanners' platform-type carriages, which in turn are attached laterally or diagonally to the supports and which can be traversed on accurately pre-adjusted precision profile rails and bearings. As the scanner traverses the moving web, it provides a cross-machine direction profile of basis weight, thickness or moisture on the display console that is a cross-section of the manufactured product. The scanning width can be predetermined in recipe, or the the product edges can be automatically tracked by the standard edge detectors to eliminate any effects of web wander.

Since the measurement-related data supplied by the sensors is processed immediately by a real-time computer in the traversing frame, it can be transferred to the central control computer via an easy-to-run network cable.



WebPro L

The WebPro L traversing frames represent the pinnacle of the Mahlo® scanning frame family. They are available in traverse widths of up to 8 meters, and can run up to five Mahlo® sensors continuously, precisely and rapidly across the online product. Applications range from the production of nonwovens at line-speeds of up to 1000 m/min, and textiles, the manufacture of fiberglass matting, various coating applications under challenging ambient conditions, paper impregnation for the makers of upholstery sheeting and laminates, PVC calendaring for floors and carpet coating, right through to the manufacture of artificial leather and plastic sheet and film extrusion coating.

WebPro M

WebPro M traversing scanners are found on a wide variety of web processing applications in an assortment of industries, and are legendary for their robust construction and superior reliability providing a low cost of ownership. Scanners of this type can handle products of up to 4 meters in width with up to a total of 3 different measurement sensors. Their compact design and ultra-precise traverse mechanisms enable them to be installed even where space is at a premium and at any angle to suit the given product / web flow.

Potential applications range from nonwoven production lines, coating lines for textiles, paper, film or floor coverings, to installations involved with the manufacture of artificial leather and extruded cast and / or calendared film or sheet.

Customer benefits

- ✓ Easy to install and connect
- ✓ A minimum of upkeep and maintenance costs, along with high availability and long service life
- ✓ The ultra-precise carriage-guide mechanism guarantees really accurate measurements from the various sensors
- ✓ Accident-proof thanks to the continuous monitoring of motor current and integrated safety cutout

Product-highlights

- ✓ Intelligent scanning frame with integrated real-time computer
- ✓ Extremely rugged, mechanical construction assures trouble-free operation and long service life
- ✓ Maintenance-friendly design
- ✓ Available in several versions, tailored for the specific application
- ✓ Constructed with commonly available standard components to ensure optimum availability of replacement parts



TEXTILE



NONWOVEN



PAPER



PLASTIC

MECHANICAL

MEASURING FRAME TYPES

UNIVERSAL APPLICATION

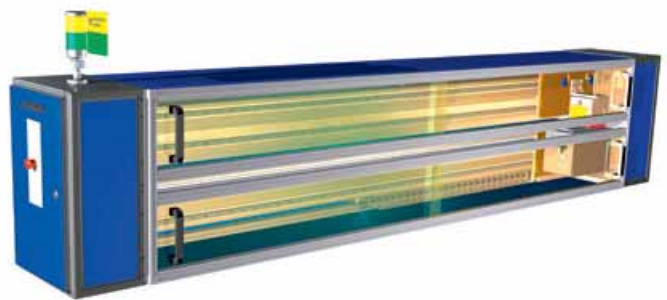

WebPro S

The WebPro S traversing frames have been designed specifically to provide an exceedingly compact but rugged and reliable traversing platform for situations where space limitations would rule out the use of a conventional O-frame. The main applications are for high-speed coating machines whose compact construction leaves very little space for installation of traditional scanning frames. These include ranges for producing adhesive tapes, label rolls, self-adhesive film, light-proof coated textile and nonwoven substrates. The WebPro S scanning frame is also to be found in the film industry.

WebPro XS

The traversing frames of the type WebPro XS are used for many applications in various industries and are distinguished especially by their rugged, reliable and compact design. Traversing frames of this type can be used for product widths from 0.2 to max. 2 meters and can accommodate one Mahlo® sensor.

The compatible design and use of precision linear slides permit installation even in restricted spaces. Possible applications range from lab coating via coating for textiles, paper, film up to systems for the manufacturing of artificial leather and extrusion coating.

Customer benefits

- ✓ Easy to install and connect
- ✓ A minimum of upkeep and maintenance costs, along with high availability and long service life
- ✓ The ultra-precise carriage-guide mechanism guarantees really accurate measurements from the various sensors
- ✓ Accident-proof thanks to the continuous monitoring of motor current and integrated safety cutout

Product-highlights

- ✓ Intelligent scanning frame with integrated real-time computer
- ✓ Extremely rugged, mechanical construction assures trouble-free operation and long service life
- ✓ Maintenance-friendly design
- ✓ Available in several versions, tailored for the specific application
- ✓ Constructed with commonly available standard components to ensure optimum availability of replacement parts



TEXTILE



NONWOVEN



PAPER



PLASTIC

MECHANICAL

MEASURING FRAME TYPES

UNIVERSAL APPLICATION



KNOWLEDGE

We have a common goal: Maximum performance from your Mahlo System. To that end we are at your side, right from the installation of the equipment and advice on how to maintain it, through to the training of your employees. Our instructors get your people in shape in matters of operating and servicing. So that you can solve your problems even faster.

UniScan M / UniScan S

The UniScan M or UniScan S traversing frames are the single-sided counterpart to the double-sided O-frames of the WebPro series, and have been specially designed to accommodate the single-sided sensing devices of the Mahlo® QMS family. This single-sided arrangement enables the frame to be easily retrofitted to existing systems, with the measuring sensors arranged above, below or at the side of the measuring frame. Possible applications include film calendering, nonwovens, pulp drying, extrusion coating and the coating or impregnation of paper, cardboard, films/foils or textiles.

Customer benefits

- ✓ Easy to install and connect
- ✓ A minimum of upkeep and maintenance costs, along with high availability and long service life
- ✓ The ultra-precise carriage-guide mechanism guarantees really accurate measurements from the various sensors
- ✓ Accident-proof thanks to the continuous monitoring of motor current and integrated safety cutout

Product-highlights

- ✓ Intelligent scanning frame with integrated real-time computer
- ✓ Extremely rugged, mechanical construction assures trouble-free operation and long service life
- ✓ Maintenance-friendly design
- ✓ Available in several versions, tailored for the specific application
- ✓ Constructed with commonly available standard components to ensure optimum availability of replacement parts

SENSORS



TEXTILE



NONWOVEN



PAPER



PLASTIC

GRAVIMAT DFI

BASIS WEIGHT (MASS PER UNIT AREA) / THICKNESS

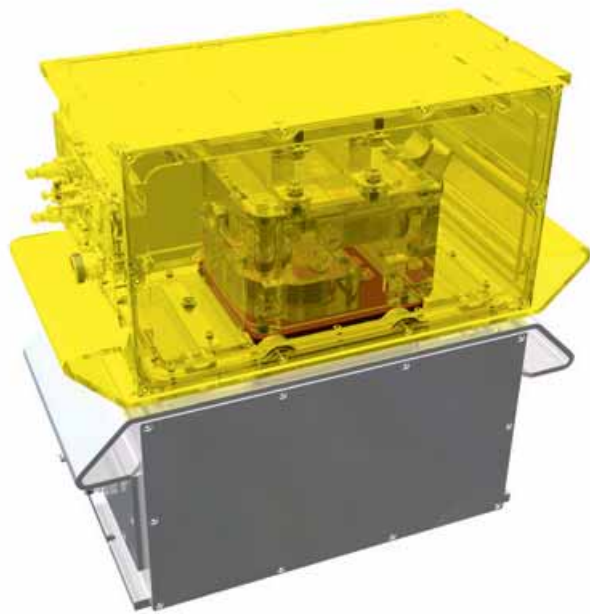

Applications

The Mahlo® DFI (Dynamic Flutter Independent) beta sensor uses a revolutionary new sensing technique that allows:

- Complete insensitivity to web flutter throughout the entire measurement gap.
- The smallest beta sources and the highest measurement performance.
- Very fast scanning speeds with ultra-narrow web defect detection.
- Long-term trouble free, cost effective operation in the harshest environments.

Virtually all web processes have problems with maintaining consistent flatness. Cast, extruded and calendered film and sheet exhibit ripples and flutter due to line tension changes, static electricity or in-line vibration. Paper and coating converters must deal with baggy substrates, edge curl and distances of unsupported web. Nonwovens and textile manufacturers see variations in the loft, density and thickness of their webs which result in center of mass changes.

Product-highlights

- ✓ Intelligent sensor with ultra-fast microprocessor for pre-processing measurements
- ✓ Precise measurements as a result of using extremely efficient beta radiation detectors
- ✓ Four temperature-compensation sensors along with air pressure compensation
- ✓ Robust, sturdy emitter housing meets the most stringent safety regulations
- ✓ Variable measuring gaps to suit customer requirements

All of these conditions result in measurement errors with traditional transmission sensors like X-ray or beta gauges. Backscatter sensors like gamma or X-ray are even more sensitive to web movement and some are even required to contact the web!

The new Mahlo® patented DFI Beta Sensor is not affected by web flutter, passline change, ripples, sag or edge curl. The DFI measures accurately throughout changes in loft, density or thickness.

Principle of operation

The Mahlo® DFI uses a multiple detector technique that captures the full measurement signal regardless of where the web is within the gap. The resulting measurement is determined only by the basis weight, not by the position of the web in the measurement gap. This solution is quite simple and industrially rugged, but it is completely effective. So effective in fact, that Mahlo® has been awarded international patents for the DFI.

No heavy absorbers or highly radioactive sources are necessary. Mahlo® supplies its Kr85 DFI with only 260 mCi or smaller sources, yet the accuracy, speed and resolution of the Mahlo® DFI are the best yet offered.

An additional advantage of the Mahlo® DFI is that measurement gaps can now be substantially increased without worrying about additional web movement. Soft, easily damaged webs, or wet coatings no longer need to run the risk of contacting the sensor due to a narrow gap. The Kr85 DFI can use measurement gaps of 2 inches and more while measuring even light weight webs!

Principle of operation, unaffected by web position

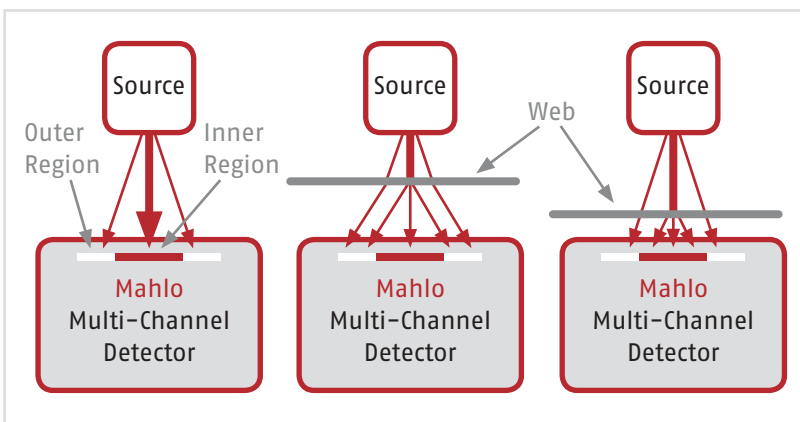

Gravimat DFI sensor response curve

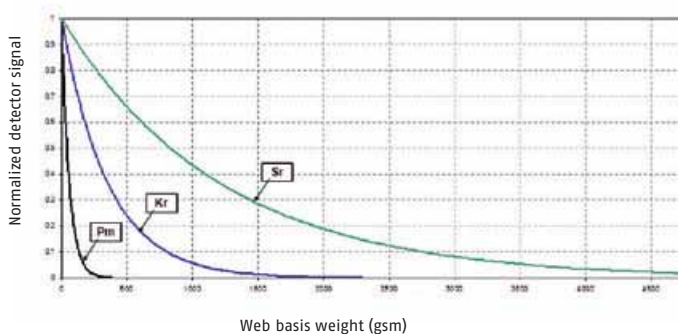

RELIABILITY

Our components do exactly what we build them for: hour after hour, year after year. Our design team ensures that the central nervous system of our equipment always works without interruption. So that you always reach your objective.

Customer benefits

- ✓ Non-destructive, continuous determination of the weight per unit area of product webs
- ✓ Highly stable and accurate measurement along with a minimum need to calibrate
- ✓ The DFI allows wider measurement gaps and avoids damage to soft webs or wet coatings
- ✓ Wide measuring range through use of various isotopes



TEXTILE



NONWOVEN



PAPER



PLASTIC

SENSORS

GRAVIMAT FMX

BASIS WEIGHT (MASS PER UNIT AREA) / THICKNESS



Applications

The Gravimat FMX sensor consists of a compact X-ray tube and its high-voltage power supply as well as special, modern X-ray detectors with the electronics for data acquisition. It is completely insensitive to environmental effects such as temperature and relative humidity. This new measuring principle is used with the proven Mahlo® components for data recording and processing, and is therefore fully compatible with other products of the Qualiscan QMS family.

The manner in which X-rays interact with mass allows for the measurement of a very wide range of web basis weights using a single sensor, from 50 - 20,000 g/m² with the web against a steel roller or in free air!

Product-highlights

- ✓ Single-sided measurement requiring a minimum of space; easy to integrate into existing systems
- ✓ Measuring device works with an X-ray tube that can be turned off, and has no radioactive isotope emitter
- ✓ Insensitive to distance-related variations due to patented detection system
- ✓ It can measure against a steel roller, thereby ensuring perfect web guiding at the measuring point
- ✓ Virtually insensitive to the chemical composition of the web thanks to 65 KV tube

GRAVIMAT FMX in place



Principle of operation

The photons from an X-ray tube are directed towards the product, from which they are partially backscattered. The backscattered photons generate a high number of pulses in the detectors, thus enabling precise and ultra-stable measurement of the weight of the web.

The detector signal generated by the X-ray backscatter increases linearly with the weight of the product. Errors traditionally associated with web position, flutter or temperature are eliminated by the sensor design. When the density is known, the thickness of the material can also be determined very accurately (film, PVC, etc.).

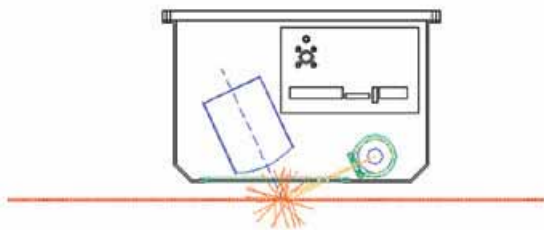

Principle of operation, schematic representation

Customer benefits

- ✓ Can be installed without having to modify the processing range and existing web guiding arrangement
- ✓ Easy to certify, and a minimum of radiation safety requirements; X-rays can be turned off
- ✓ Highly accurate and virtually insensitive to product composition
- ✓ Extremely wide measuring range using the same instrument without modification or redesign

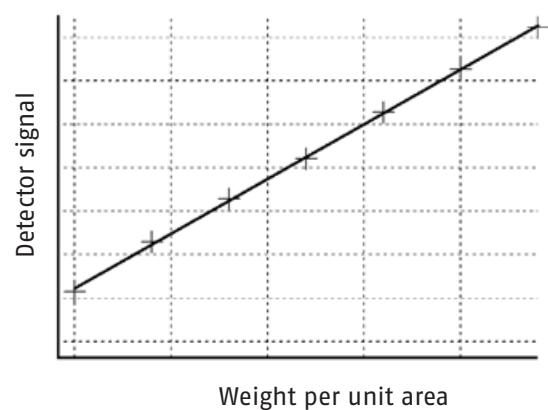

Gravimat FMX measurement diagram

SENSORS



TEXTILE



NONWOVEN



PAPER



PLASTIC

AQUALOT AMF/HMF

MOISTURE MEASUREMENT

Applications

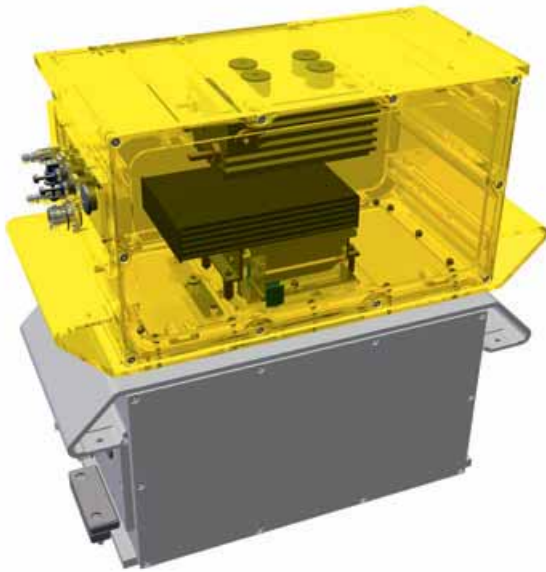

Product moisture is an extremely important parameter for the manufacturer and processor of web products such as paper, textiles, cardboard and nonwovens. Microwave-absorption technology has been used for quite some time to determine this quantity online, but up to now, limited resolution has restricted its use to measurement of larger quantities of water, thus preventing it from being used to measure thinner products or lower levels of moisture. With this patented measuring technique it is possible to detect even the smallest amounts of water exceedingly accurately and with a high degree of stability, thereby enabling it to be used on even thin printing paper, airbag materials or the nonwovens used in the hygiene sector, without its accuracy being affected by product colour or composition.

Sensor model DS-115

Product-highlights

- ✓ Highly accurate and stable measurement thanks to microwave-resonance analysis
- ✓ Unaffected by the color of the product web or its chemical composition
- ✓ Temperature compensation by using a pyrometer to detect product temperature
- ✓ Servo-motor controlled tracking of the lower resonance chamber in traversing mode (sensor model DS-115)

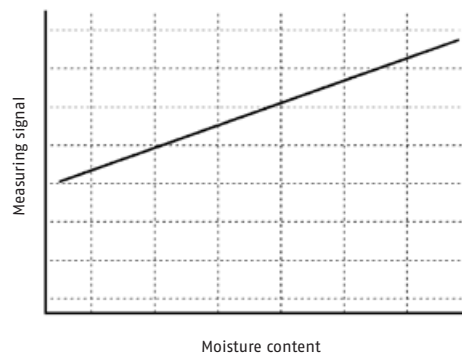

Principle of operation

The sensor consists of two parts, which together form a resonance chamber, and the product passes through the centre of this divided chamber. A microwave emitter stimulates two standing waves in the resonance chamber, whereby one of the two corresponds to the absorption wavelength of the water molecules in the microwave spectrum and the second serves as a reference. Contrary to the traditional absorption technique, the Aqualot HMF device evaluates the shift in the resonant frequency of the two standing waves with respect to each other rather than the attenuation of the microwaves by the quantity of water molecules in the measuring gap. This patented "microwave resonance" principle is virtually insensitive to changes in product composition, an advantage that helps keep the number of product-specific calibrations to a minimum. In addition, the device is characterised by its ability to resolve to an exceedingly high degree even the lowest percentages of moisture, thereby extending the use of microwave technology significantly in comparison with traditional measuring techniques.

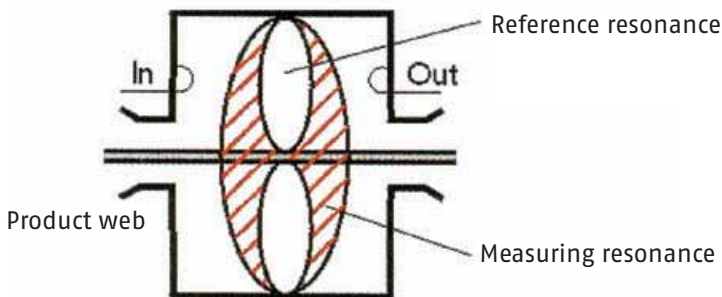

Principle of measurement

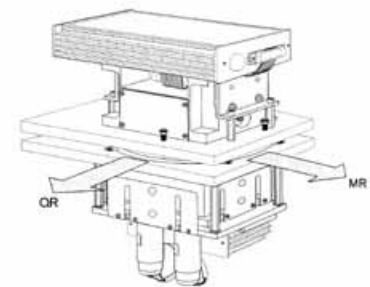

Automatic scanner centring

Customer benefits

- ✓ Non-destructive, continuous determination of the amount of moisture (H_2O) in product webs
- ✓ Extremely accurate and stable measurements; calibration reduced to a minimum
- ✓ Long life expectancy through the use of high-quality components
- ✓ Wide measuring range through the use of various resonance configurations

SENSORS



TEXTILE



NONWOVEN



PAPER



PLASTIC

INFRALOT IMF

MOISTURE AND ORGANIC COMPOUND MEASUREMENT

Applications

By optically analysing reflected light energy in the near-infrared range (NIR), the Mahlo® IMF sensor can measure online, non-destructively and without adversely affecting the product's characteristics important product-specific parameters such as moisture (water), coating weight, the thickness of plastic film, or the organic components in nonwovens. The NIR backscatter sensors of the Infralot IMF series are based on the classic 6-filter measuring principle, but are updated with the very latest optical components and in accordance with the most recent trends in optical measuring technology.

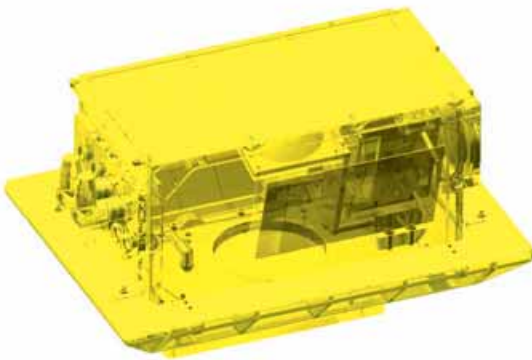

Product-highlights

- ✓ Beam generation by means of a robust halogen lamp
- ✓ High-speed filter wheel with six optional filters
- ✓ Easy to install, non-critical with respect to product distance and impurities
- ✓ Can be calibrated by the customer by means of a simple gauging tile
- ✓ Detectors cooled by an integrated, regulated Peltier element
- ✓ Easy access to the measuring optics for cleaning purposes

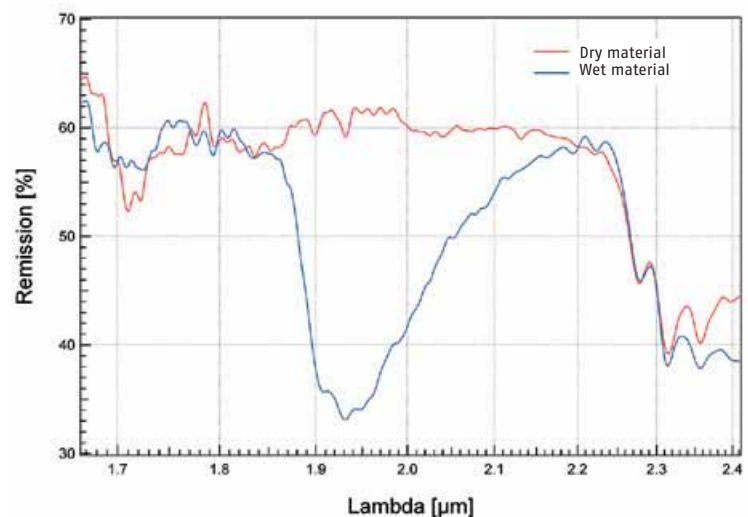

Infralot IMF diagram

Principle of operation

Light-specific wavelengths can induce the atomic bonds of certain molecules to oscillate at a multiple of their basic frequency, whereby the major portion of the incidental light energy is absorbed by the product. If the light reflected from a product is evaluated for its energy separately for each wavelength, a relationship between the degree of absorption of these resonant wavelengths and the number of absorbing molecules can be determined. The graph shows this clearly. Dependent on the amount of moisture in the product, the light energy absorbing alters significantly at the resonant wavelength of the water molecule. To obtain a stable measurement in practice, the reflected light energy at the resonant wavelength is compared with other non-absorptive wavelengths (references).



LISTENING

Our sales team knows how to listen: with our customers' individual requirements, wishes and ideas firmly in mind, they point our R&D engineers in the right direction. Consequently, you get exactly what you really need.

Customer benefits

- ✓ Non-destructive, continuous analysis of various web or sheet parameters
- ✓ Exceedingly accurate and stable measurements; calibration reduced to a minimum
- ✓ Long life expectancy through the use of high-quality components
- ✓ Wide range of applications by using various measuring wavelengths

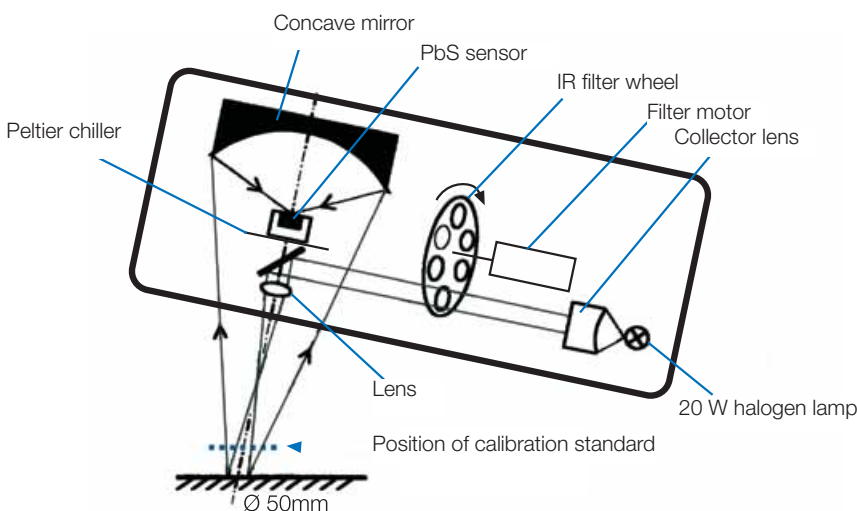

Schematic representation of the IMF measuring principle

SENSORS



TEXTILE



NONWOVEN



PAPER



PLASTIC

CALIPRO DML

NON-CONTACT THICKNESS GAUGE

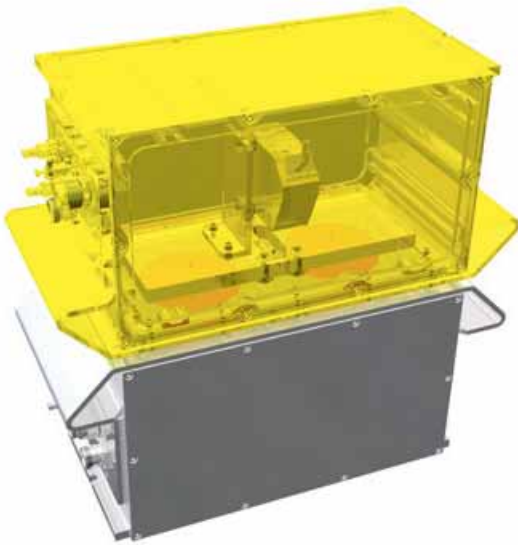

Applications

In principle, the two-sided, non-contact, laser-type thickness gauge can be used to monitor virtually any product in web or sheet form. Successful applications for this technique can be found in the paper and cardboard industry, nonwoven sector, plants manufacturing PVC flooring or other calendered or extruded plastic webs and sheets, and in the manufacture of artificial leather.

Product-highlights

- ✓ Non-contact, non-destructive and ultra-precise measurement online of product thickness
- ✓ Available in several configurations to accommodate a wide range of web thicknesses and accuracy requirements
- ✓ Can gauge either at one side against a reference roller or on both sides
- ✓ Opaque, translucent and transparent webs can be measured with high precision
- ✓ High sampling rate and resolution of the cross-web profile

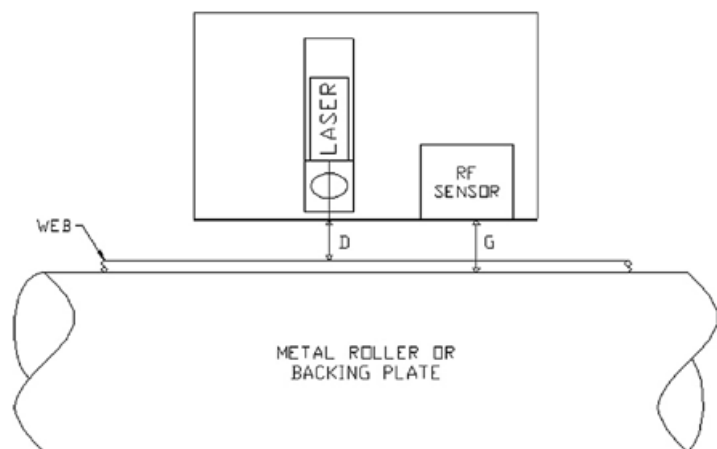

Calipro DML, single-sided version

Principle of operation

Either one or two laser-triangulation sensors determine the exact distance between the gauging sensor(s) and product surface, either from one or both sides. Depending on the arrangement, the addition of high-precision eddy-current sensors, determines either the distance between the two gauging sensors or the distance between the one sensor and a reference roller.

The thickness of the product is then determined by evaluating the difference between the two measured values. This is done by the Calipro DML's built-in microprocessor, which at the same time synchronises the upper and lower lasers and, on certain versions, processes in real-time the data measured by the numerous temperature sensors which compensate for any temperature-related dimensional changes in the housing.

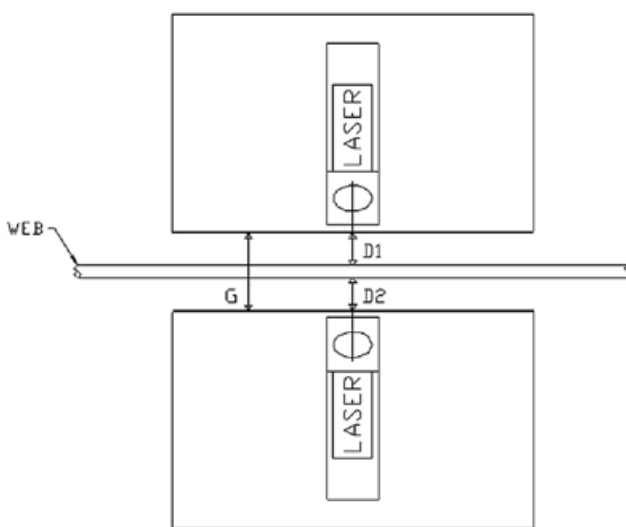

Calipro DML with two-sided laser sensor



PROMPT INSTALLATION

Our service team ensures that the installation of our equipment runs smoothly and on-time. So that your investment is turned quickly into profit.

Customer benefits

- ✓ Determines the thickness of a web or sheet directly without reference to product density
- ✓ Since the gauge is able to traverse, it indicates the thickness of the product from edge to edge
- ✓ Non-contact measurement has no adverse effect on either product quality or the manufacturing process
- ✓ Insensitive to variations in the surface of the product, hence a high degree of measurement-related stability

SENSORS



TEXTILE



NONWOVEN



PAPER



PLASTIC

CALIPRO DML-P

CONTACT MEASUREMENT OF THICKNESS

Product-highlights

- ✓ Simple, non-destructive and high-precision determination online of product thickness
- ✓ Available in several forms for various measuring ranges
- ✓ On smooth running webs, measurement is virtually contact-free thanks to the air cushion

Applications

The air cushion principle lends itself especially for very slow running webs with a dense, close-textured surface. It is ideal for calendered, transparent film, on which the laser technique may struggle due to insufficient reflection of the laser beam from the surface of the film. The sensor can also be used to good effect on slow-running paper or cardboard sheet, provided that linespeed does not exceed 100 m/min.

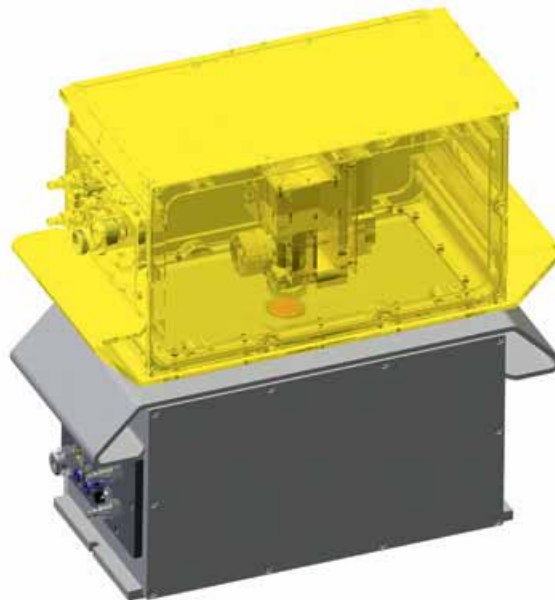

Principle of operation

Two plungers, one each above and below the web are gently pressed against it by a finely adjusted volume of compressed air. At the surface of the plungers, a precisely defined volume of air is emitted through finely bored holes. This forms an air cushion above and below the web so that the plungers virtually float over the surface of the online sheet.

In each of the two plungers is a coil, which together form an inductance. By varying the distance between the coils (ie. product thickness), the inductance changes, and by connecting a capacitor in series with them, the resonant frequency of the oscillator thus formed varies in accordance with the thickness of the product.

Customer benefits

- ✓ Determines the thickness of the product web directly
- ✓ Indicates the thickness of the web from one edge to the other
- ✓ Completely insensitive to variations in the surface of the product
- ✓ Can be used to gauge even highly transparent products, e.g. PET or PA film



Quality made
in Germany

For decades we have been developing and producing our machines exclusively in Germany – using the highly motivated specialists we have trained ourselves. This is your guarantee of the highest level of quality.

66¹⁹⁴⁵₂₀₁₁ YEARS
MAHLO



TEXTILE



NONWOVEN



PAPER



PLASTIC

OPTIONS

DIECONTROL APC PRO

AUTO DIECONTROL

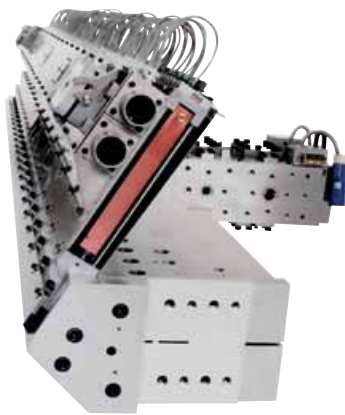

Extrusion die*



Product-highlights

- ✓ Exceedingly short recovery times by using optimised "feed-forward" control algorithms
- ✓ Modular construction facilitates maintenance and expandability
- ✓ Automatic improvement of power-factor by varying the switching time points
- ✓ Features such as predictive Neck-In Compensation and Edge-Bead Control are industry firsts

Applications

The DieControl APC Pro thermal die controller can be used with all the usual extrusion dies which can regulate via thermal die elements the amount of coating applied cross-sheet, eg. "Autoflex™" dies from EDI, USA (Extrusion Dies Incorporated). These dies are used chiefly for film extrusion (cast film) and extrusion coating. They can also be used on special applications such as the manufacture via a coating process of special membranes on high-precision, guided steel bands. Regardless of the application, the DieControl APC Pro is used to compensate for set-point errors in the thickness or g/m2 weight of the product, specifically in those segments of the extrusion die in which these errors occur. The DieControl APC Pro is usually coupled to one of the QMS Qualiscan's sensing systems, which continuously detects these errors across the entire width of the sheet, and transmits this profiling data to the DieControl APC Pro via a data bus link.

Fundamentals

The main panel contains the thyristor-based power controls for the individual thermal die bolts of the extrusion die, one per segment (max. 256 per unit). This is normally installed close to the die to avoid long cable runs and is connected to the operating unit. Power output is regulated for each thermal die bolts by a duty cycle. Varying the latter's ratio changes the output, which in turn alters the temperature of the die accordingly. As a consequence the length of the element also changes and, as the latter is directly attached to the lip applicator, the temperature of the die also alters the profile of the lip, and this then acts upon the cross-sheet profile of the extruded polymer (film thickness, coating weight).

All control loops are operated in real-time by an independent PLC which communicates directly with the power actuators and regulates the duty cycle. The operating screens are typically integrated into the main QMS-12 Console display: all parameters entered into the PC are sent to the PLC via a TCP/IP interface, thereby ensuring optimum, fail-safe processing. The control algorithms support both types of extrusion dies, i.e. "push" and "push-pull", and in doing so, reliably prevent damage to the die lips as a result of incorrect control actions.

Customer benefits

- ✓ Fully automatic reduction of repetitive errors in cross-sheet thickness (coating)
- ✓ A marked improvement in the quality of the end product
- ✓ Instant control ensures a minimum of lost production when changing batches
- ✓ Considerable savings in raw material thanks to a minimum of set-point errors
- ✓ Automatic reduction of operator errors thanks to closed-loop control



Recipe settings for die control



TEXTILE



NONWOVEN



PAPER



PLASTIC

OPTIONS

COATCONTROL CWS

COAT WEIGHT CONTROL

Product-highlights

- ✓ Control parameters individually adapted to suit the coating mechanism
- ✓ Operated via the the touch screen interface of the QMS control system
- ✓ Minimal hardware expenditure along with maximum results

Customer benefits

- ✓ Fully automatic reduction of repetitive errors in cross-sheet coating thickness
- ✓ Significant improvement in the quality of the end product permits higher selling prices
- ✓ Instant control ensures a minimum loss of production when changing batches
- ✓ Considerable savings in raw material owing to a minimum of set-point errors
- ✓ Minimal intervention by operating personnel thanks to intelligent software
- ✓ Automatic reduction of operator errors as a result of closed-loop control

Applications

The CoatControl CWS can be used wherever a QMS control system is used to continuously monitor online the weight of a coating applied to a product, and the installation's coating or application mechanism allows automatic control of either the mean weight of coating, or even left / right distribution.

Fundamentals

PID closed-loops with incremental relay outputs (plus / minus) can be used to automatically control either the speed (rpm) of a coating (lick) roller (with counter roller) or the gap and tilt of the rollers with respect to each other in order to obtain the desired amount of coating. Up to four output channels per coating mechanism are provided to control either the distribution of coating at the left, centre and right of the sheet or the mean weight of coating applied.

In addition to traditional lick roller mechanisms, the CoatControl CWS can also control calenders to regulate cross-sheet thickness.

To enable it to do so, the coating mechanism must be equipped with suitable actuators and servo drives which can be controlled by electrical impulses. Usually, the CoatControl CWS controls directly the servo motor fitted to the coating mechanism or calender.

SERVICE AND SUPPORT

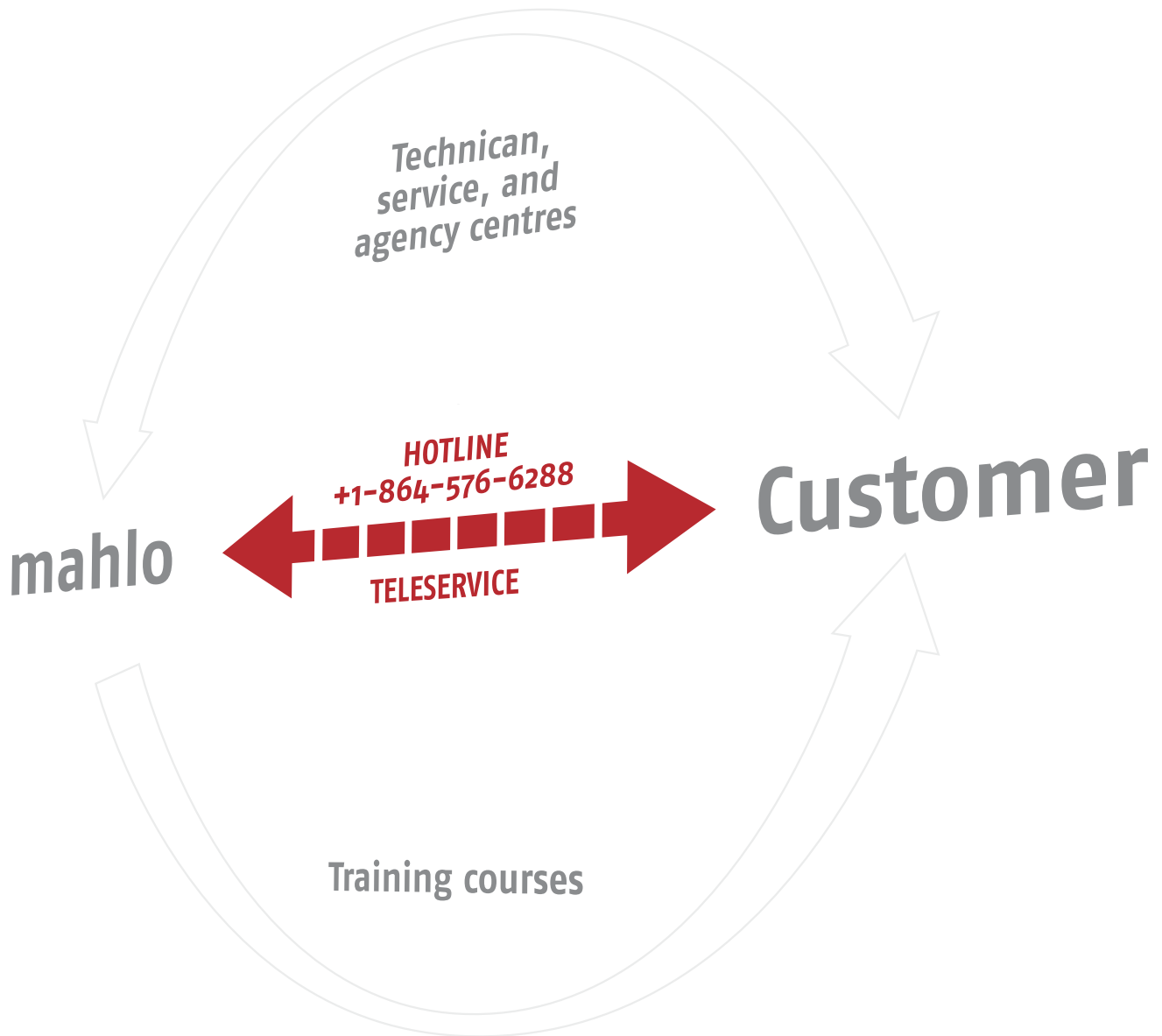

Mahlo® has for decades been setting standards in the field of measuring and control systems for the textile industry: using innovative and trend-setting technology.

In addition to technology, direct contact with our customers is especially important to us. This includes intensive assistance and customer care wherever the customer is located, a global service and agency network and our 24-hour replacement part service.

We wish to convey to you the good feeling and security of being able to count on the know-how of our experts in any situation, regardless of whether it concerns installation and start-up, conversion of existing systems or the servicing of your appliances.

TECHNICAL DATA | WEBPRO L

Scanning frame	WebPro L
Scanner width	Web width: 800 – 6400 mm
Scanning speed	50 – 500 mm/s
Sensor payload	Five sensors, both upper and lower carriages
X-, Y-, Z-axis runnout	X (scan axis [CD]), $\pm 300 \mu$ (± 0.3 mm) Y (machine axis [MD]), $\pm 100 \mu$ (± 0.1 mm) Z (vertical axis), $\pm 150 \mu$ (± 0.15 mm)
Scan location repeatability	$\pm 250 \mu$ (± 0.25 mm)
Operating temperature (without cooling)	0 – 45 °C
Cooling scanning frame	Air purging with cooled compressed air
Cooling sensors	Scanner is plumbed as standard for compressed air or liquid cooling (some components optional)
Intrinsic safety	1. Air purging to meet class 1, division 1 requirements U.S. National Electric Code (optional) 2. Purging & pressurization for explosion proof environments, according to ATEX zone 1 or zone 2, category 2
High corrosion environment	Full stainless steel protective covers available (optional)
Power	230 V AC, 50 Hz or 115 V AC, 60 Hz (to be specified with order)
Interface	TCP/IP (Ethernet)

Dimensions

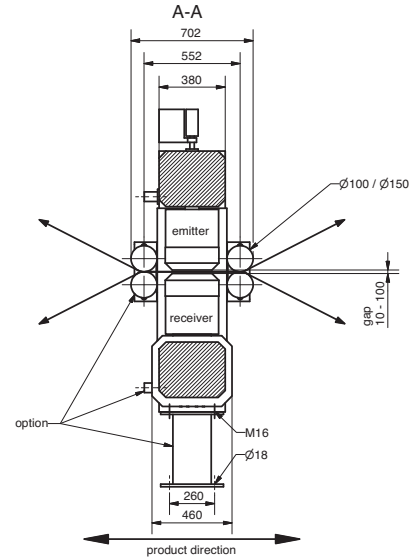
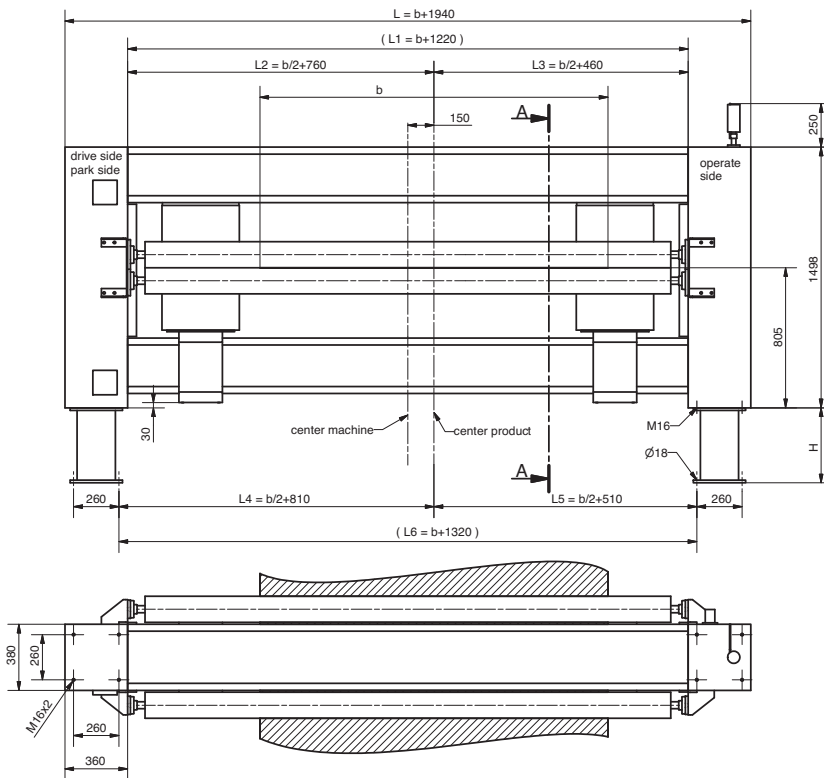

b = product width, all dimensions in mm

Machine width depends on number of sensors

Measuring frame WEBPRO L
91-015020-01



FIRST AID

You can count on our service team, especially when "first-aid" is required. A call is all it takes to get our technicians on-site. Around the clock – and around the globe. So that you can concentrate on your work without having to worry.



Online-Support:
SERVICE@MAHLOAMERICA.NET

Support-Hotline:
+1-864-576-6288

TECHNICAL DATA | WEBPRO M

Scanning frame	WebPro M
Scanner width	Web width: 800 – 4000 mm
Scanning speed	20 – 300 mm/s
Sensor payload	Three sensors, both upper and lower carriages
X-, Y-, Z-axis runnout	X (scan axis [CD]), < 300 μ (< 0.3 mm) Y (machine axis [MD]), < 100 μ (< 0.1 mm) Z (vertical axis), < 150 μ (< 0.15 mm)
Scan location repeatability	± 250 μ (± 0.25 mm)
Operating temperature (without cooling)	0 – 45 °C
Cooling scanning frame	Air purging with cooled compressed air
Cooling sensors	Scanner is plumbed as standard for compressed air or liquid cooling (some components optional)
Intrinsic safety	1. Air purging to meet class 1, division 1 requirements U.S. National Electric Code (optional) 2. Purging & pressurization for explosion proof environments, according to ATEX zone 1 or zone 2, category 2
High corrosion environment	Full stainless steel protective covers available (optional)
Power	230 V AC, 50 Hz or 115 V AC, 60 Hz (to be specified with order)
Interface	TCP/IP (Ethernet)

Dimensions

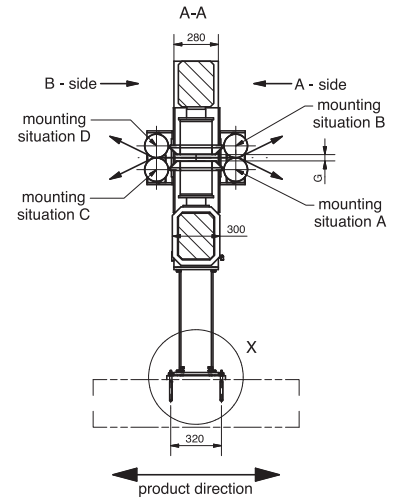
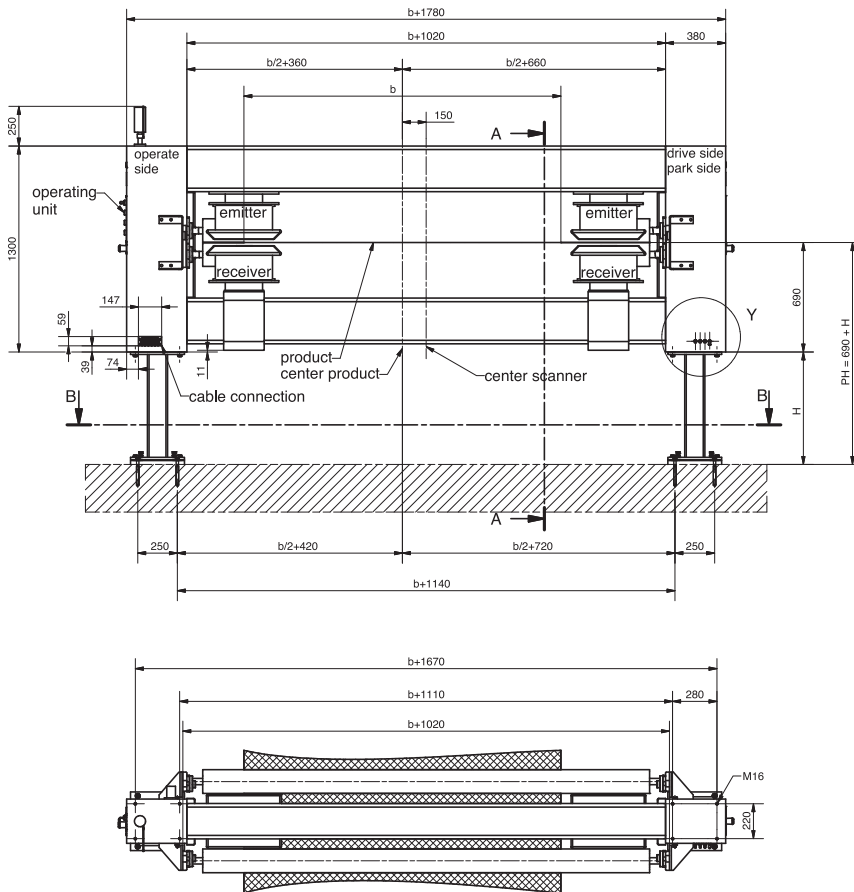

b = product width
 G = gap
 H = height pedestal
 PH = product height
 F = force

Measuring frame WEBPRO M
 91-015450



PERSONALITY

You're not just a number to us. Your individual needs and special requirements are our highest priority. We are there for you with our expertise, trend-setting technology and full dedication. So you can always play to win.

TECHNICAL DATA | WEBPRO S

Scanning frame	WebPro S
Scanner width	Web width: 600 – 3400 mm
Scanning speed	30 – 300 mm/s
Sensor payload	Two sensors, both upper and lower carriages
X-, Y-, Z-axis runnout	X (scan axis [CD]), ± 300 μ (± 0.3 mm) Y (machine axis [MD]), ± 100 μ (± 0.1 mm) Z (vertical axis), ± 100 μ (± 0.1 mm)
Scan location repeatability	± 250 μ (± 0.25 mm)
Operating temperature (without cooling)	0 – 45 °C
Cooling scanning frame	Air purging with cooled compressed air
Cooling sensors	Scanner is plumbed as standard for compressed air or liquid cooling (some components optional)
Intrinsic safety	1. Air purging to meet class 1, division 1 requirements U.S. National Electric Code (optional) 2. Purging & pressurization for explosion proof environments, according to ATEX zone 1 or zone 2, category 2
Power	230 V AC, 50 Hz or 115 V AC, 60 Hz (to be specified with order)
Interface	TCP/IP (Ethernet)

Dimensions

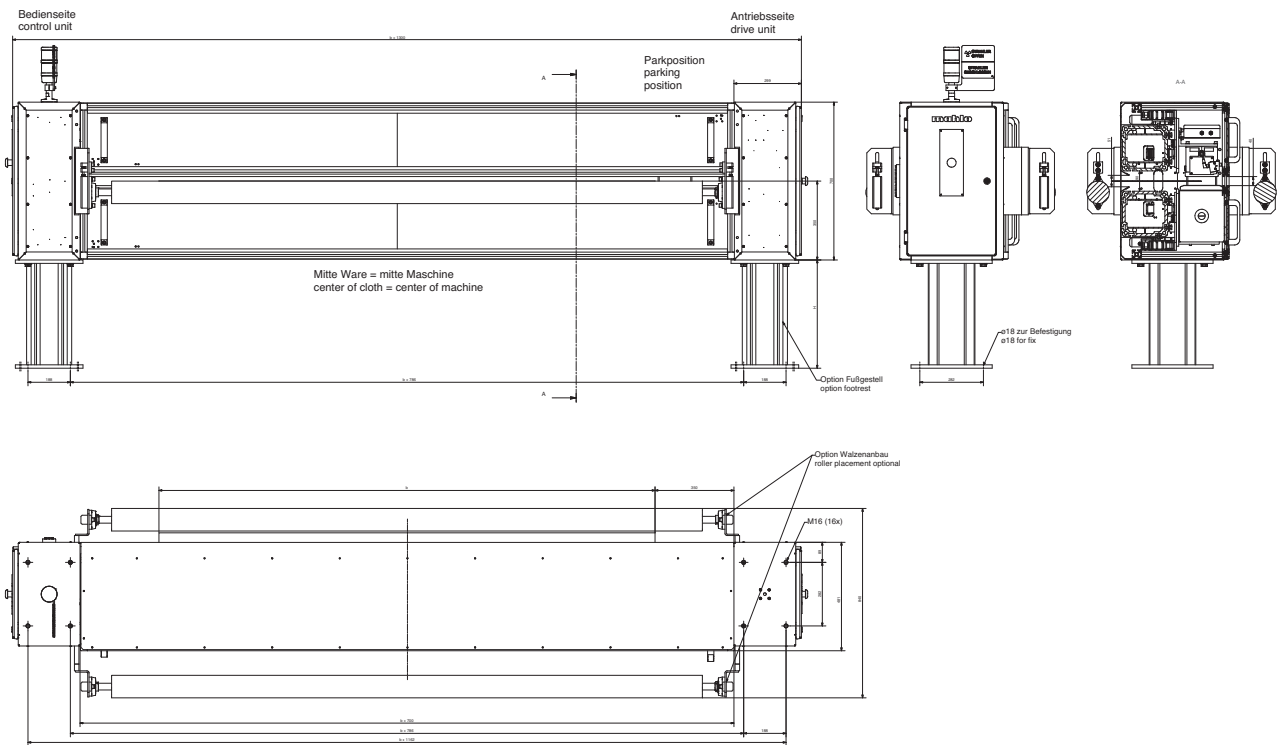

Measuring frame WEBPRO S
91-013104-02



AROUND THE CLOCK

We know every nut and bolt on our machines. Your replacement part will be on its way to you within 24 hours. We set everything in motion. Just so that you don't stand still.

Online-Support:
SERVICE@MAHLOAMERICA.NET

Support-Hotline:
+1-864-576-6288

TECHNICAL DATA | WEBPRO XS

Scanning frame	WebPro XS
Scanner width	Web width: 200 – 2000 mm
Scanning speed	20 – 200 mm/s
Sensor payload	One sensor
X-, Y-, Z-axis runnout	X (scan axis [CD]), $\pm 300 \mu$ ($\pm 0.3\text{mm}$) Y (machine axis [MD]), $\pm 300 \mu$ ($\pm 0.3\text{mm}$) Z (vertical axis), $\pm 200 \mu$ ($\pm 0.2\text{mm}$)
Scan location repeatability	$\pm 250 \mu$ ($\pm 0.25 \text{ mm}$)
Operating temperature (without cooling)	0 – 45 °C
Measuring devices cooling	All measuring devices are optionally equipped with cooling function and measuring gap purging with compressed air
Power	1 ~ 230/115 V AC, 50/60 Hz (through connection in base switching cabinet)
Max. power consumption	1 kVA
Interface	TCP/IP (Ethernet)

Dimensions

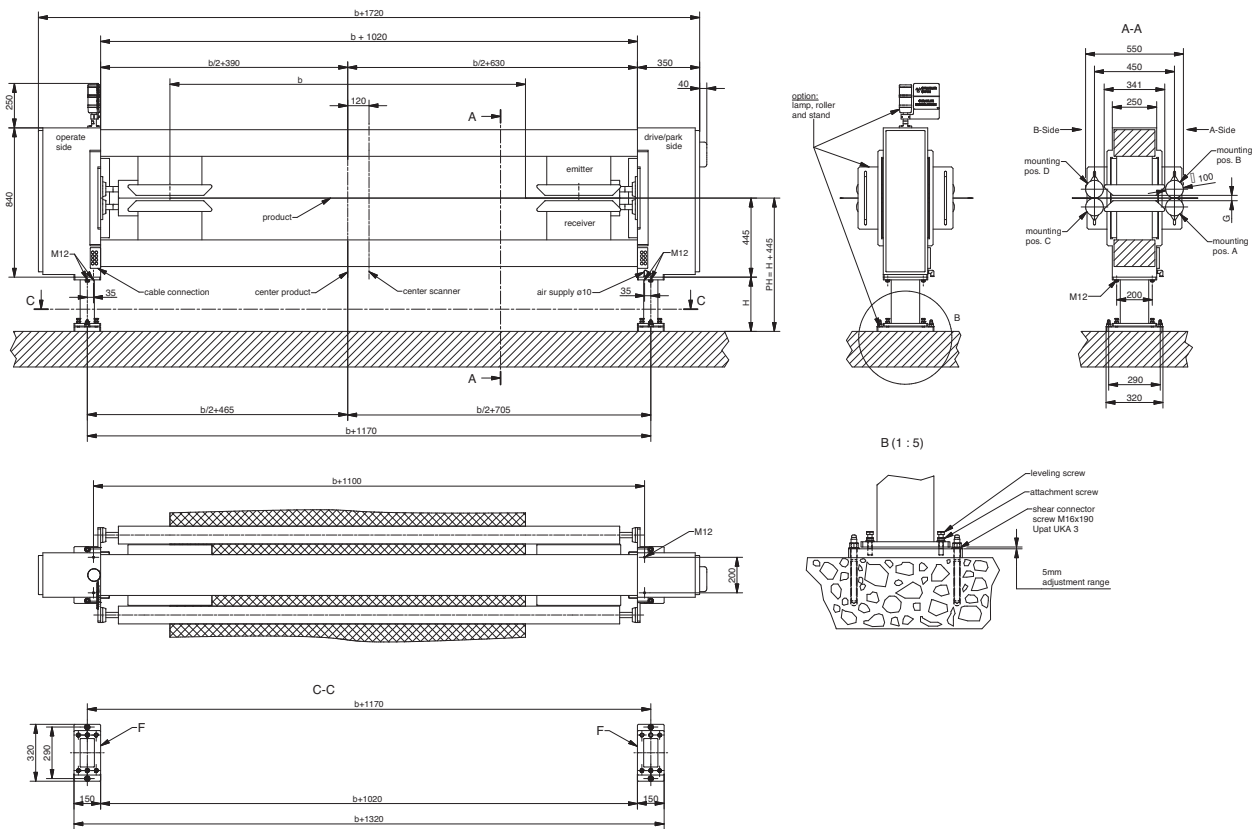

Measuring frame WEBPRO XS
91-015735



INNOVATIONS

We love being technological leaders. And our R&D team works every day to make sure it remains so. Innovations, inventive talent and future-oriented thinking – to guarantee your success.

TECHNICAL DATA | UNISCAN M

Scanning frame	UniScan M
Scanner width	Web width: 600 – 6400 mm
Scanning speed	30 – 300 mm/s
Sensor payload	Three sensors, mounted to the carriage
Scan location repeatability	± 250 μ (± 0.25 mm)
Operating temperature (without cooling)	0 – 45 °C
Cooling scanning frame	Air purging with cooled compressed air
Cooling sensors	Scanner is plumbed as standard for compressed air or liquid cooling (some components optional)
Intrinsic safety	1. Air purging to meet class 1, division 1 requirements U.S. National Electric Code (optional) 2. Purging & pressurization for explosion proof environments, according to ATEX zone 1 or zone 2, category 2
Power	230 V AC, 50 Hz or 115 V AC, 60 Hz (to be specified with order)
Interface	TCP/IP (Ethernet)

Dimensions

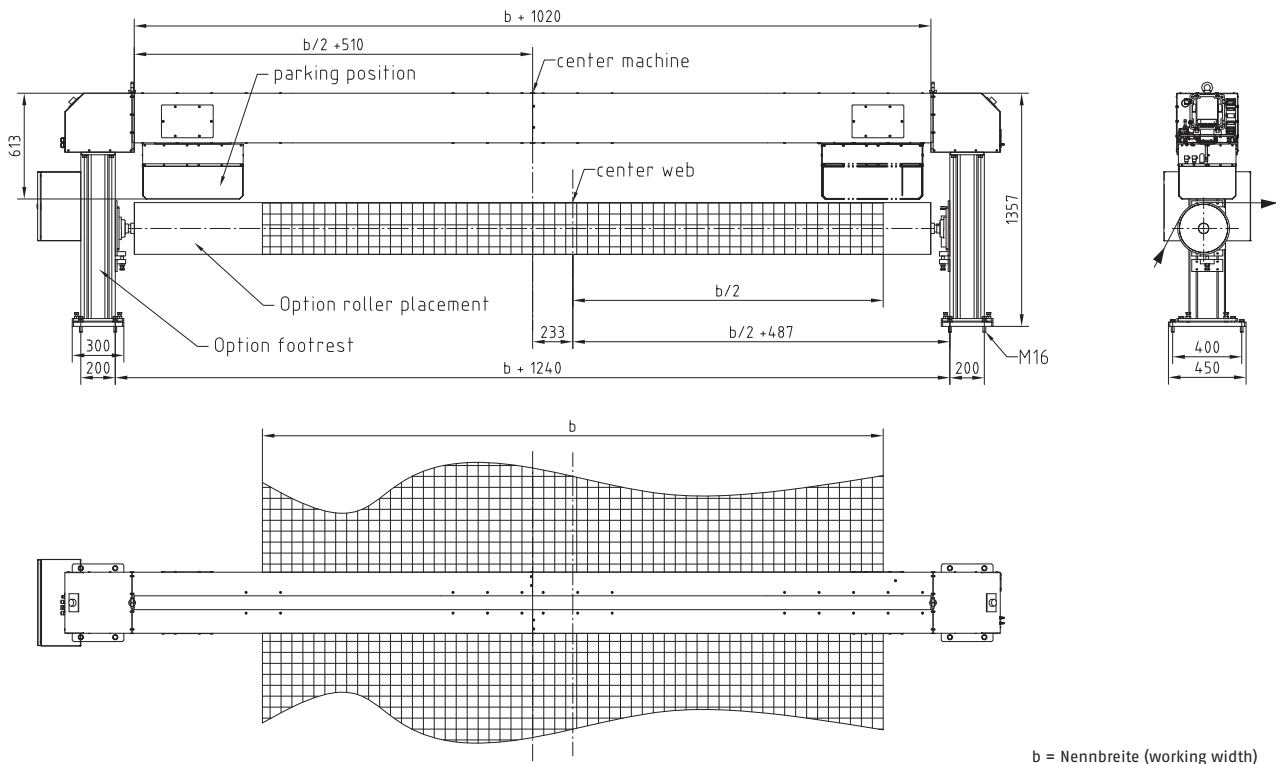

b = Nennbreite (working width)

Measuring frame UNISCAN M
for GRAVIMAT FMX sensor
91-013784

TECHNICAL DATA | UNISCAN S

Scanning frame	UniScan S
Scanner width	Web width: 600 – 3400 mm
Scanning speed	30 – 300 mm/s
Sensor payload	One sensor
Scan location repeatability	$\pm 250 \mu$ (± 0.25 mm)
Operating temperature (without cooling)	0 – 45 °C
Power	230 V AC, 50 Hz or 115 V AC, 60 Hz (to be specified with order)
Interface	TCP/IP (Ethernet)

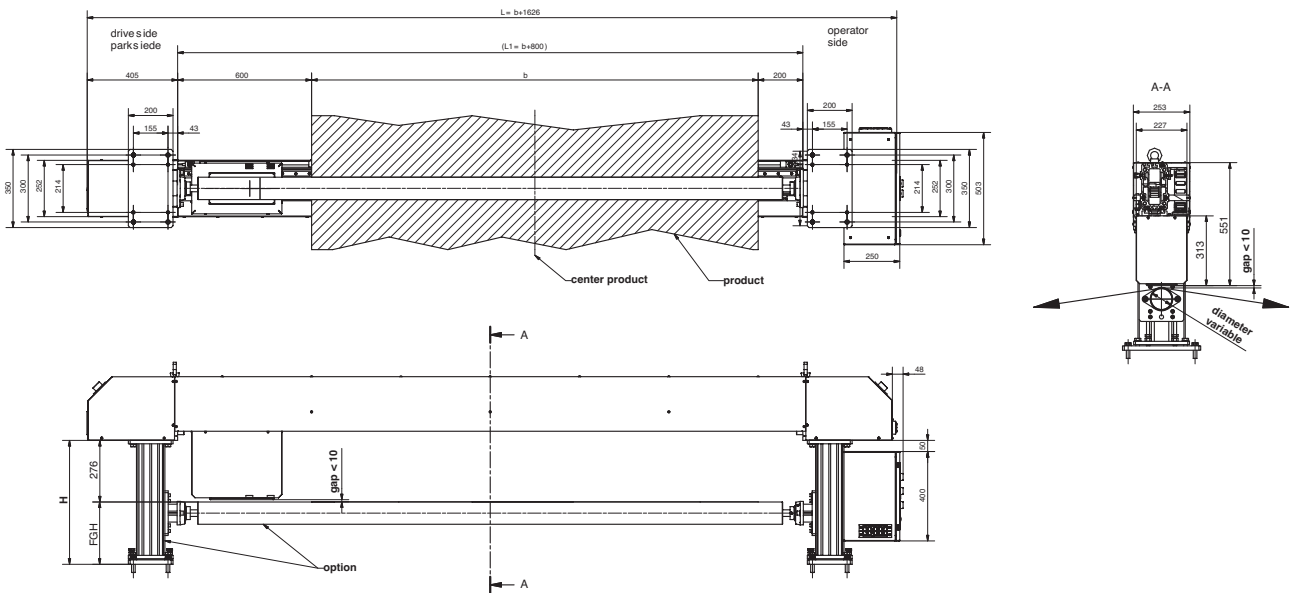

Measuring frame UNISCAN S for CALIPRO DML sensor
91-014959-02

Dimensions

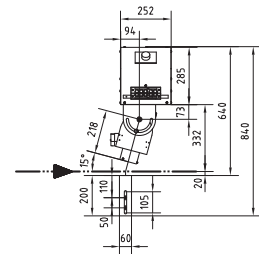
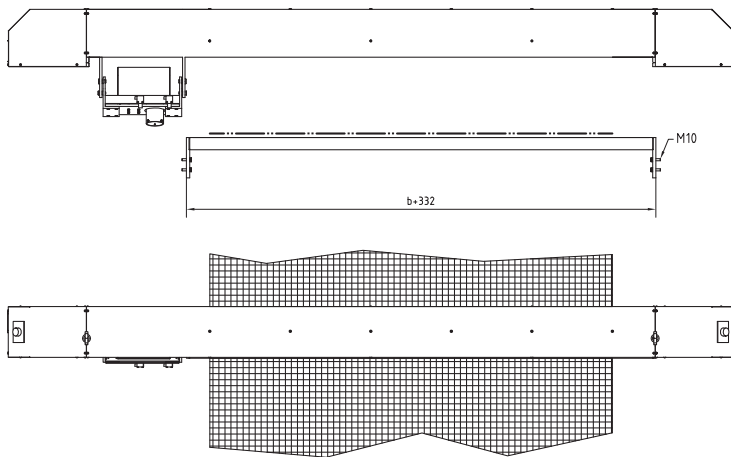
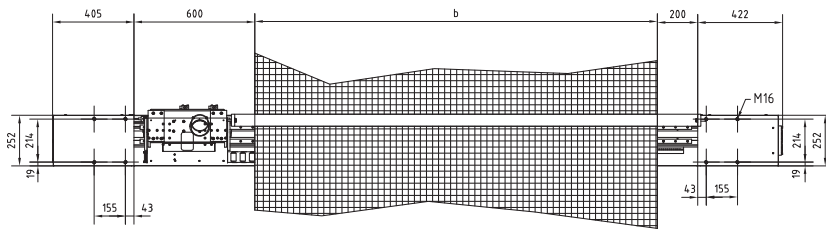

b = Nennbreite (working width)

Measuring frame UNISCAN S for
INFRALOT IMF sensor
91-013511



DEVELOPMENT

To ensure high-performance capability and maximum customer benefit from our products, we rely on the latest technologies and maximum commitment to develop the products of tomorrow. So that the future can start for you today.

TECHNICAL DATA | GRAVIMAT DFI

Sensor	Gravimat DFI		
Isotope	Promethium-147	Krypton-85	Strontium-90
Activity	1000 mCi (37 GBq)	400 mCi (15 GBq) or 260 mCi (9.6 GBq) or 80 mCi (2.9 GBq)	20 mCi (750 mBq)
Range (basis weight) (grams / square meter)	2.5 - 160 g/m ²	10 - 1400 g/m ²	100 - 5000 g/m ²
Repeatability (2 σ , 1 s) (the greater)	± 0.05 % or ± 0.05 g/m ²	± 0.1 % or ± 0.1 g/m ² (80 mCi: t = 4 s)	± 0.3 % or ± 0.5 g/m ²
Measurement gap	10 - 20 mm	10 - 100 mm	10 - 100 mm
Temperature compensation	At 4 locations (source and detector enclosures, measurement gap at source and detector faces)		
Barometric compensation	Electronic, included in C&D console		
Passline / flutter tolerance	100 % of measurement gap from 10 - 40 mm (minimum of 2.4" within larger gaps)		
A/D conversion resolution	16 bit (1/65536 FS)		
Power supply	24 V DC		
Maximum ambient conditions	Max. 60 °C, 0 - 95 % relative humidity (non-condensing) higher temperature applications upon request		
Maximum current useage	Source max. 1 A (continuous: 0.5 A)	Detector max. 2 A (continuous: 0.3 A)	

Dimensions

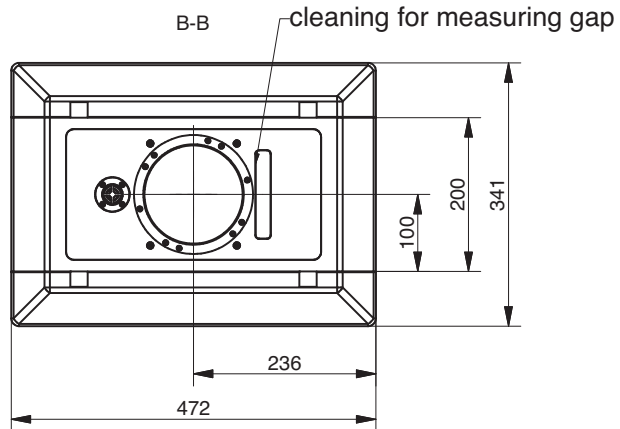
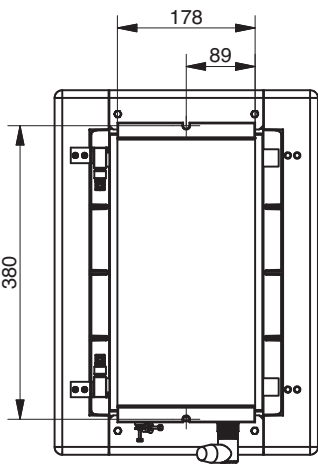
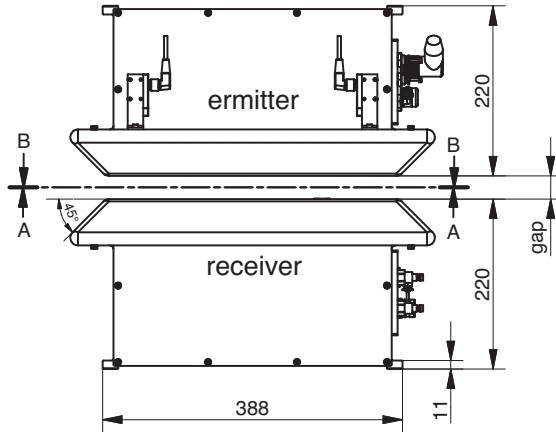
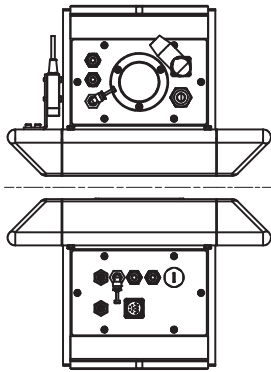

A-A

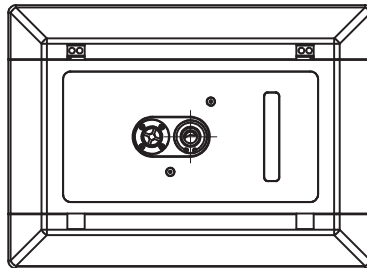

GRAVIMAT DFI sensor
91-015583

TECHNICAL DATA | GRAVIMAT FMX • AQUALOT AMF/HMF

Sensor	Gravimat FMX
Measurement	X-ray backscatter sensor
Beam generator	X-ray tube
Measuring range	50 - 20000 g/m ²
Accuracy	± 0.4 g/m ² at 100 g/m ² ± 1.0 g/m ² at 500 g/m ² ± 2.5 g/m ² at 2000 g/m ²
Distance sensor-product	15 - 50 mm (standard 20 mm)
Distinctive feature	Can measure against a steel roller or free air
Cooling	Water (circulation)
Power supply	24 V DC
Ambient limits	Max. 60 °C, 0 - 95 % relative humidity (higher temperature applications upon request)

Dimensions

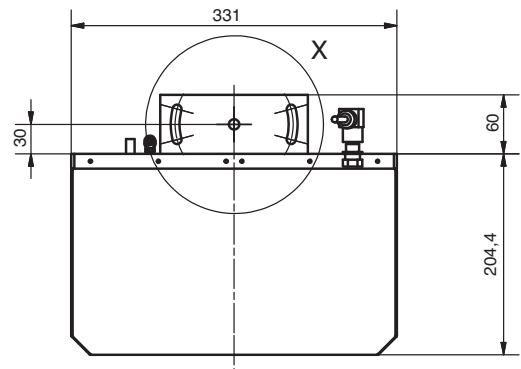
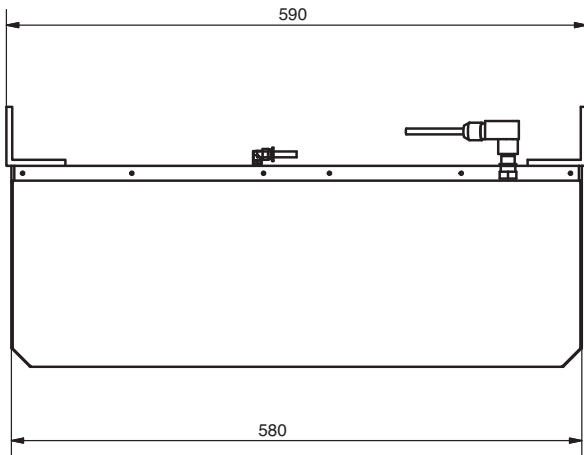

X (1 : 2)

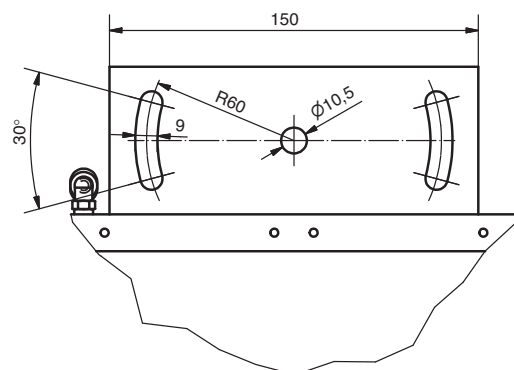

GRAVIMAT FMX sensor
91-013782

Sensor	Aqualot AMF/HMF			
Measurement principle	Microwave resonance			
Model	DS-115			DS-20
Measurement range	1	2	3	
Water weight	1 - 25 g/m ²	1 - 50 g/m ²	1 - 100 g/m ²	1 - 600 g/m ²
Resolution	± 0.01 g/m ²	± 0.02 g/m ²	± 0.04 g/m ²	± 0.1 g/m ²
Measurement gap	10 mm			13 - 23 mm
Power supply	24 V DC			
Operation limits	Max. 70 °C (or higher with water cooling)			

Dimensions

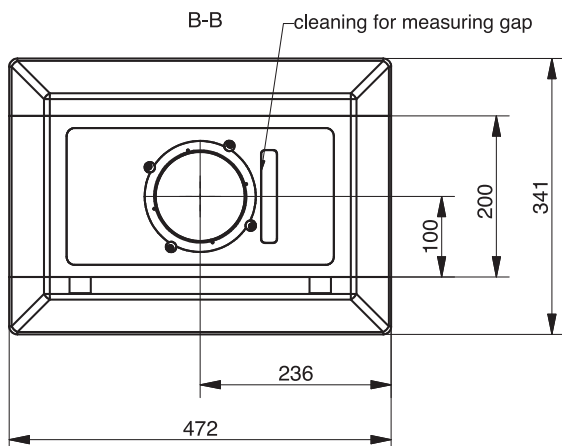
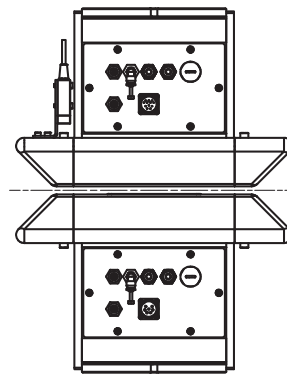
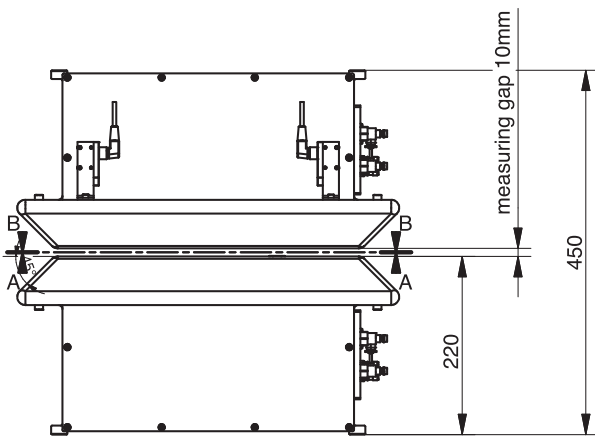

AQUALOT AMF/HMF sensor
(model DS-115)
91-015272

TECHNICAL DATA | INFRALOT IMF

Sensor	Infralot IMF
Measurement	Near infrared backscatter sensor
Wavelength band filter	1000 – 2800 nm
Measuring range	Moisture: 0.1 – 95 % absolute Coating weight: 0.5 – 500 g/m ² Organic constituents: 2 – 1000 g/m ²
Distance to product	130 – 250 mm (standard: 150 mm)
Length of air-purge union	125 mm
Scanning spot diam.	30 mm (at a distance of 150 mm), (smaller measurement spot upon request)
Life of lamp	Lifetime guarantee
Scan duration (internal)	25 ms
Power supply	24 V DC
Ambient limits	Max. 60 °C, 0 – 95 % relative humidity (non-condensing)



AROUND THE CLOCK

We know every nut and bolt on our machines. Your replacement part will be on its way to you within 24 hours. We set everything in motion. Just so that you don't stand still.

Online-Support:

SERVICE@MAHLOAMERICA.NET

Support-Hotline:

+1-864-576-6288

Dimensions

A-A (1:5)

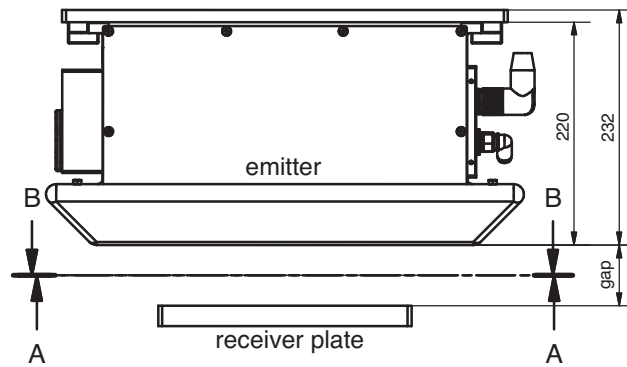
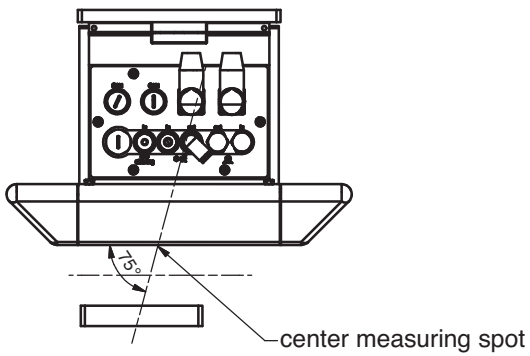
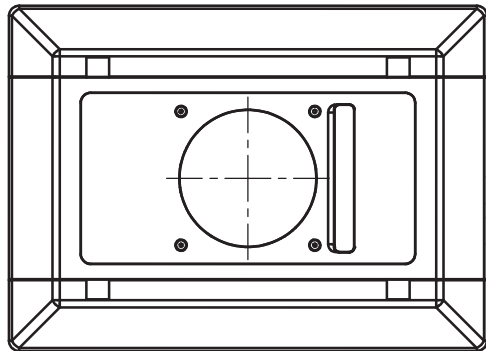

INFRALOT IMF sensor
91-017190

TECHNICAL DATA | CALIPRO DML

Sensor	Calipro DML						
Configuration	Single sided (against reference roller made of stainless steel)				Double sided (one sensor on top and bottom)		
Type designation	DML-S				DML-D		
Type number	11- 201465	11- 201980	11- 201466	11- 012522	11- 201464	11- 012457	11- 012672
Measurement principle	Laser-Triangulation plus RF-Sensoren	Laser-Triangulation plus RF-Sensoren	Laser-Triangulation		Laser-Triangulation plus RF-Sensoren	Laser-Triangulation	
Measuring range	0 – 20 mm	0 – 20 mm	0 – 30 mm	0 – 80 mm	0 – 15 mm	0 – 30 mm	0 – 80 mm
Accuracy +/-	15 µm ^[1] 20 µm ^[2]	20 µm ^[1] 30 µm ^[2]	30 µm ^[1] 150 µm ^[4]	30 µm ^[1] 150 µm ^[4]	15 µm ^[3]	50 µm ^[3]	80 µm ^[3]
Maximum measurement gap	20 mm	20 mm	30 mm	80 mm	15 mm	30 mm	80 mm
A/D-conversion resolution	16-Bit (1/65536 FS)						
Power supply	24 V DC						
Operation limits	Max. 60 °C, 0 – 95 % relative humidity (non-condensing)						
Options	Air purging, Air- or water cooling, Stainless steel housing						

¹ under laboratory conditions on ceramic plates with a stationary roller and fixed position.

The measurement accuracy is highly dependent on the measurement object or its surface.

² with a rotating roller at fixed position without material to be measured

³ under laboratory conditions on ceramic plates with traversing sensors

⁴ dependent on the concentricity of the roller

Dimensions

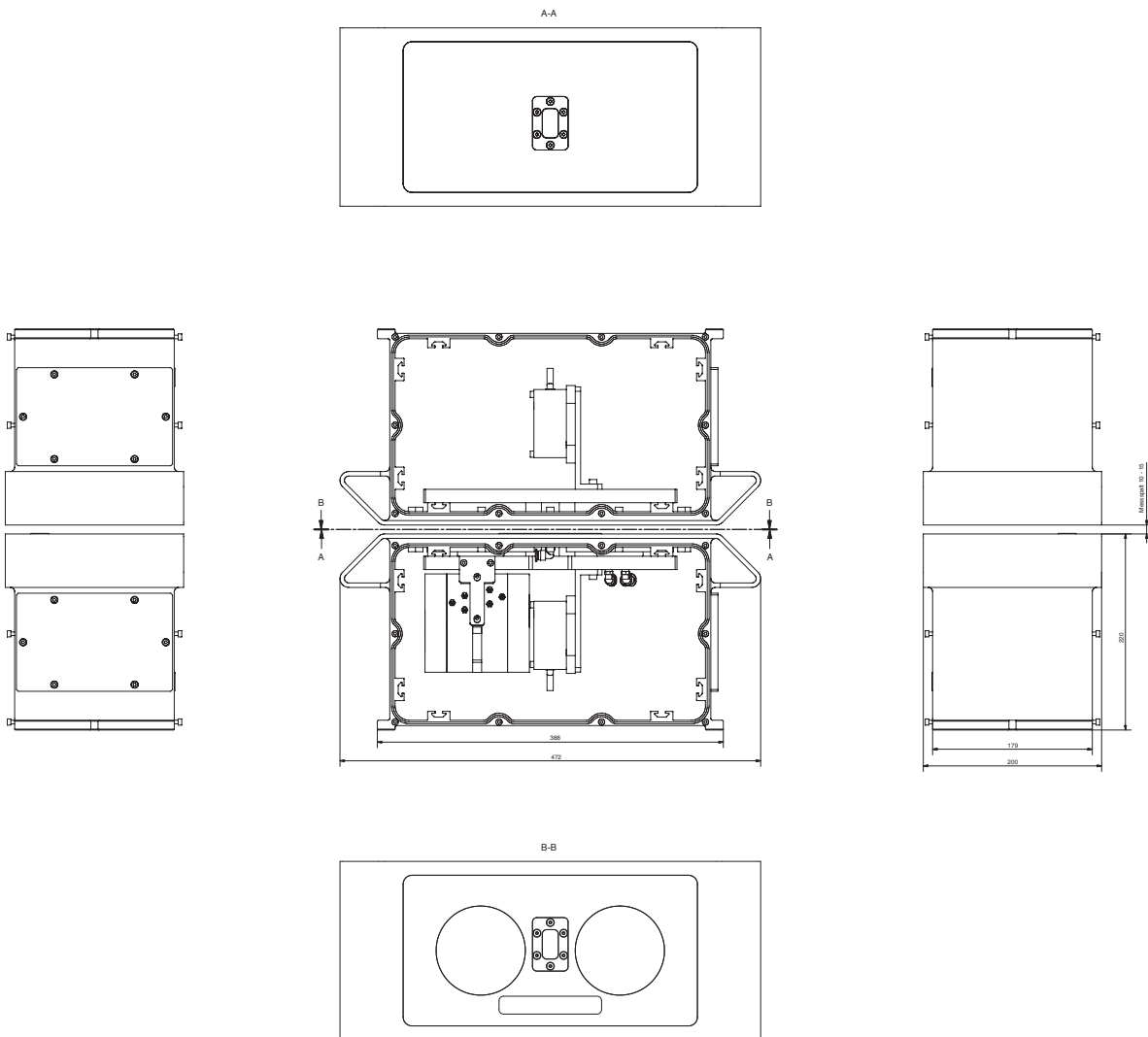

CALIPRO DML sensor
91-201464

TECHNICAL DATA | CALIPRO DML-P

Sensor	Calipro DML-P
Configuration	Double sided (one sensor on top and bottom)
Type designation	DML-P
Type number	11-012463
Measurement principle	Measurement piston with air cushion
Measuring range	0 - 4 mm
Accuracy +/-	6 μm ^[1]
Maximum measurement gap	15 mm
A/D-conversion resolution	16-Bit (1/65536 FS)
Power supply	24 V DC
Operation limits	Max. 60 °C (140 °F), 0 - 95 % relative humidity (non-condensing)
Options	Air purging, Air- or water cooling, Stainless steel housing

¹ under laboratory conditions on ceramic plates with traversing sensors

Dimensions

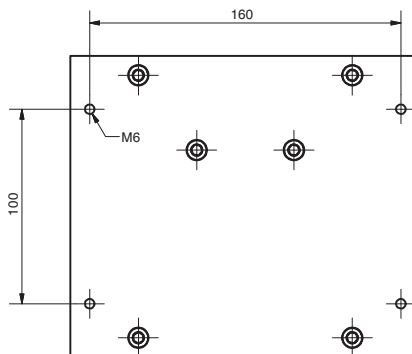
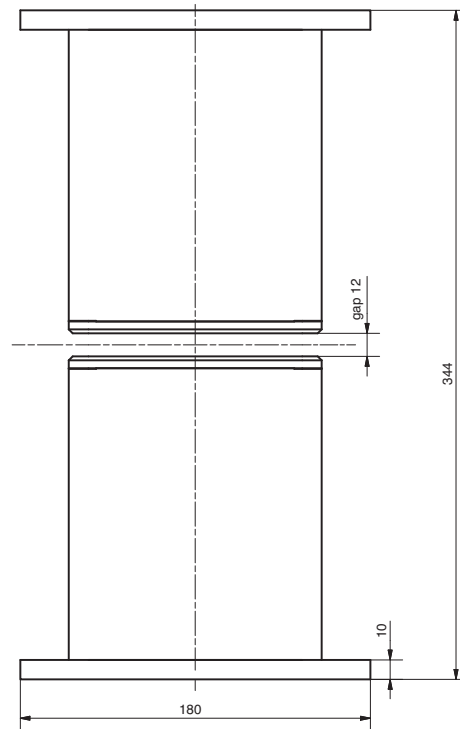
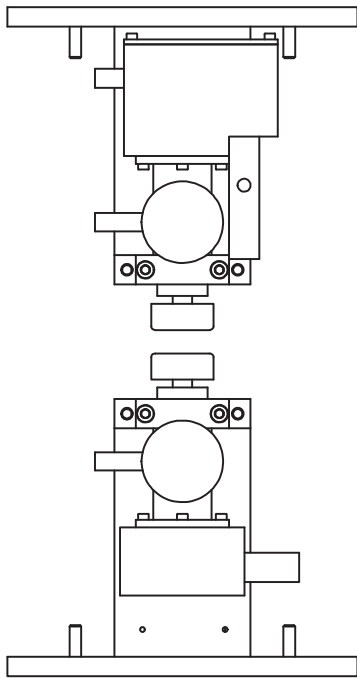

CALIPRO DML-P sensor
91-200757

TECHNICAL DATA | DIECONTROL APC PRO

Technical Data	DieControl APC Pro
Max. number of power outputs	256 (32 PCBs, each 8 channels)
Max. switching power	110/240 V AC, 1.25 A per bolt
Controller	B+R™ PLC
Connection	TCP/IP
Power supply	440/480 V AC 50/60 Hz
User interface	APC Pro software (Win32)
Control loops	Predictive, based on die model
Dimensions of control cabinet	600 x 1072 x 450 mm



CONTINUANCE

Our decades of experience has made us the reliable partner which we are today. Independent, determined and forward-thinking. So that we can also be here for you tomorrow.

Dimensions

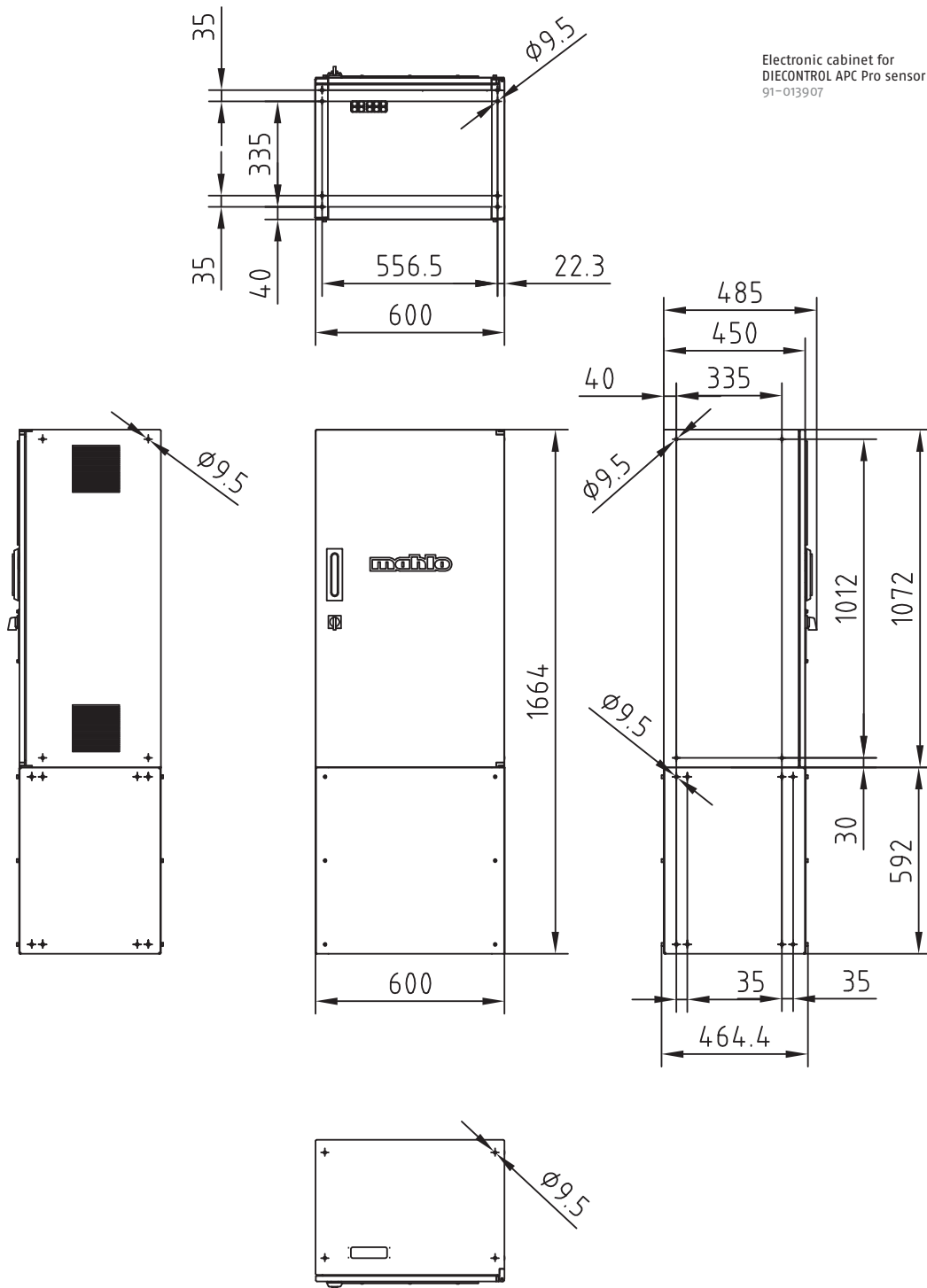

TECHNICAL DATA | COATCONTROL CWS

Technical Data	CoatControl CWS
Number of outputs (per coater)	2 - 4 (L/M/R/Average)
Type of outputs	Digital, incremental \pm (24 V DC or 250 V / 6 A)
Controller	PID micro-controller - (TQ C167)
Connection	TCP/IP (RJ 45 or industrial ethernet)
Power supply	24 V DC (provided by QMS main I/O)
User interface	QMS software (Win32)
Control loops	PID, with configurable parameters

Dimensions

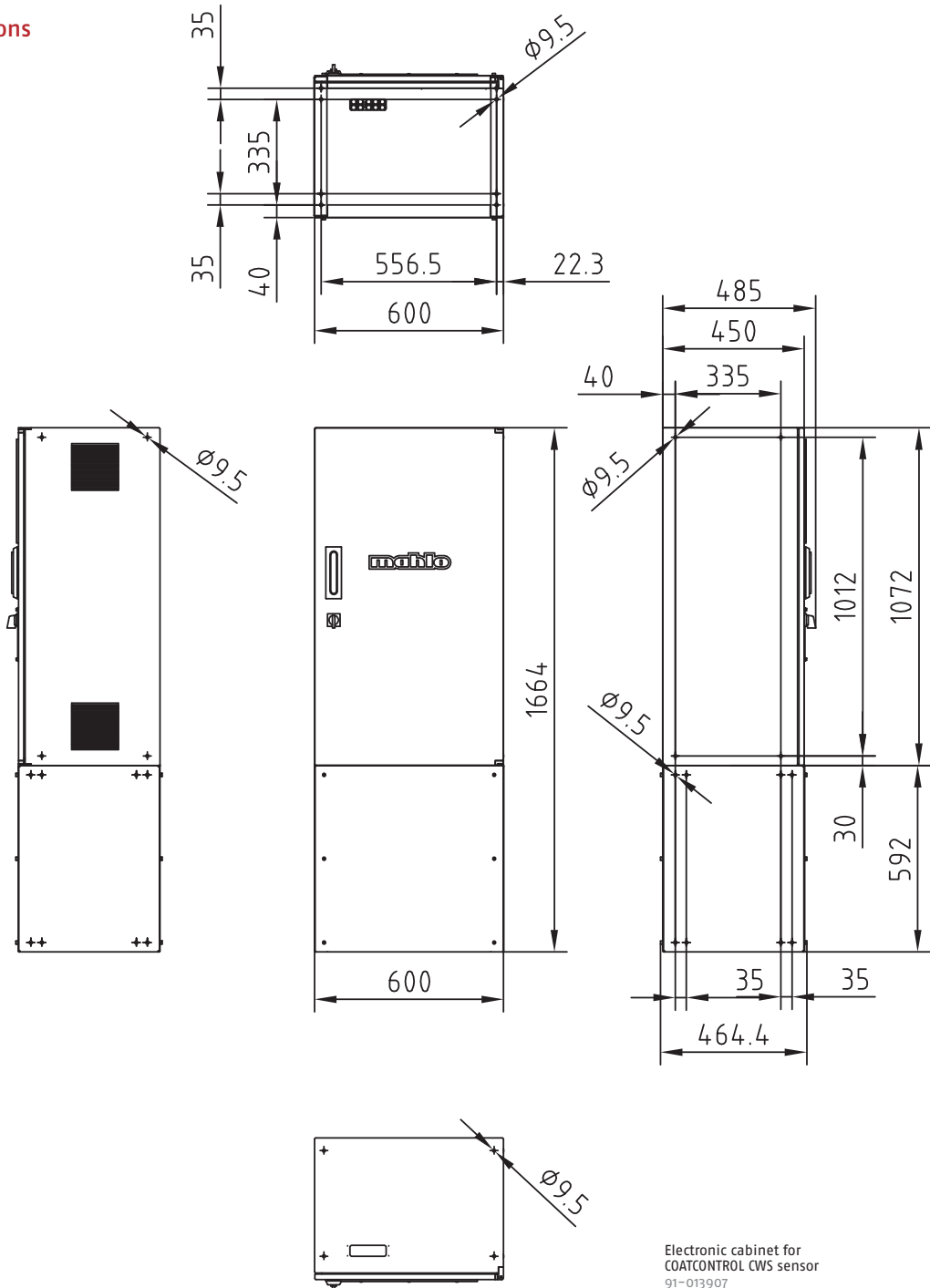

Monitoring and control systems, automation:

MAHLO® GUARANTEES QUALITY. WORLDWIDE, IN YOUR VICINITY.

Best-possible technical support and transfer of know-how are written in capital letters at Mahlo®. Thanks to an international network of agencies and service centres, customers have at their disposal competent support worldwide. We are there for you 365 days a year, 24 hours a day. Just get in touch with us!

- ✓ Over 40 service centres worldwide
- ✓ Prompt service and supply of spare parts within 24 hours
- ✓ Remote diagnostic system
- ✓ Service-hotline: +1-864-576-6288



Overall management of Mahlo GmbH + Co. KG and all subsidiary companies:

Rainer Mestermann, Dipl.-Ing. (FH)

Alois Böckmann, State-certified Business Economist

Mahlo GmbH + Co. KG Germany

Donaustr. 12, 93342 Saal/Donau

Contact: Rainer Mestermann

Tel.: +49-9441-601-0

Fax: +49-9441-601-102

info@mahlo.com

Mahlo Italia S.R.L. Italy

Via Fiume 62, 21020 Daverio

Contact: Michel Bruni

Tel.: +39-0332-94-95-58

Fax: +39-0332-94-85-86

mahlo.italia@mahlo.com

Mahlo America Inc. USA

P.O. Box 2825, Spartanburg, S.C. 29304

Contact: Alan Lavore

Tel.: +1-864-576-62-88

Fax: +1-864-576-00-09

info@mahloamerica.net

Mahlo España S.L. Spain

C/ Santa Margarida, s/n - Nave nº13

Poligono Industrial Riera de Caldes - Boada Vell

E08184 Palau Solità i Plegamans (Barcelona)

Contact: Jordi Grass

Tel.: +34-90-20062-30

Fax: +34-90-20062-40

mahlo.espana@mahlo.com

Mahlo Ouest S.P.R.L. Belgium

Quartum Center

Hütte 79 - Bte 10

4700 Eupen

Contact: Manfred Havenith

Tel.: +32-87-59-69-00

Fax: +32-87-59-69-09

mahlo.ouest@mahlo.com

Mahlo do Brasil Controle de Processos Ltda.

Brazil

R. Brigadeiro Faria Lima, 354A - Jd. Santana

Americana, SP CEP 13478-210

Contact: Jordi Grass

Tel.: +55-19-3407-7954

mahlo.brazil@mahlo.com

WWW.MAHLO.COM

QUALISCAN QMS-12 84-010319-006-us
Subject to revision! © Mahlo GmbH + Co. KG



Quality made
in Germany

66 YEARS
1945
2011
MAHLO